



**MOTOR SICH
JSC**

GAS-TURBINE POWER GENERATING UNITS

**«МОТОР СИЧ PAES-2500,
PAES-2500B,
EG-2500»**



MOTOR SICH JSC PAES-2500, PAES-2500B, EG-2500 POWER GENERATING UNITS

OPERATE

- within the temperature range of -50 to +45°C
- on gaseous or liquid fuel
- at base and peak conditions
- supplying power to independent load and in parallel with the network

PROVIDE

- high quality of energy generated
- reliability and service life durability
- automatic synchronizing with the main network and similar power generating units
- level of noise and emissions within the limits of sanitary standards

INCLUDE

- gas turbine engine and starting unit
- generator and unitized switchgear
- fuel supply and lubricating systems
- engine and generator control panel
- inlet and exhaust noise silencers
- set of spare parts, tools, devices and mounting equipment
- maintenance publications

ARE TRANSPORTED

- by road
- by rails
- by water
- by air

ARE OPERATED

- at minimum consumer's expenses
- under constant supplier's supervision
- in temperate and tropical climatic zones

GUARANTEED ARE

- high service level
- quality repair of engine and other facilities
- assistance of manufacturer's skilled specialists

CONTENTS

Motor Sich JSC is a reliable business partner

Part 1 Family of power generating units 2.5 MW power

Part 2 Gas-turbine engines of AI-20DME (AI-20DMN)
AI-20DMECh (AI-20DMNCh) models

MOTOR SICH JSC

- ❑ Zaporozhye Motor Sich JSC, with its headquarters plant founded in 1916, for a long time occupies with confidence a deserving place among the world's leading aircraft engine-building companies. Long way has been passed from creating and putting into production the aircraft water-cooled piston engines to production of up-to-date competitive in the world market turbojet, turbofan and propfan engines, as well as industrial gas-turbine drives and power generating units.
 - ❑ The products manufactured by the Company are operated in 114 countries world-wide.
 - ❑ The quality system has been certified by the Bureau Veritas Quality International (BVQI) transnational company for compliance with requirements of the ISO 9001 International Standard as regards manufacture, overhaul, and aftersales support of aircraft engines and D-336 family gas-turbine drives as well as development of gas-turbine power stations to be certified in the United States.
 - ❑ High quality and reliability of manufactured products are ensured by the use of advanced technologies, modern equipment and high level of production engineering.
 - ❑ Services provided include: marketing, export/import, guarantee and post-guarantee maintenance, overhaul and current repairs, training of technical personnel, foundation of overhaul facilities, selling licences, patents, and know-how.
- You may find Motor Sich not only as a highly potential and efficient Company, but as a reliable partner, which is always ready to satisfy customer's demands.

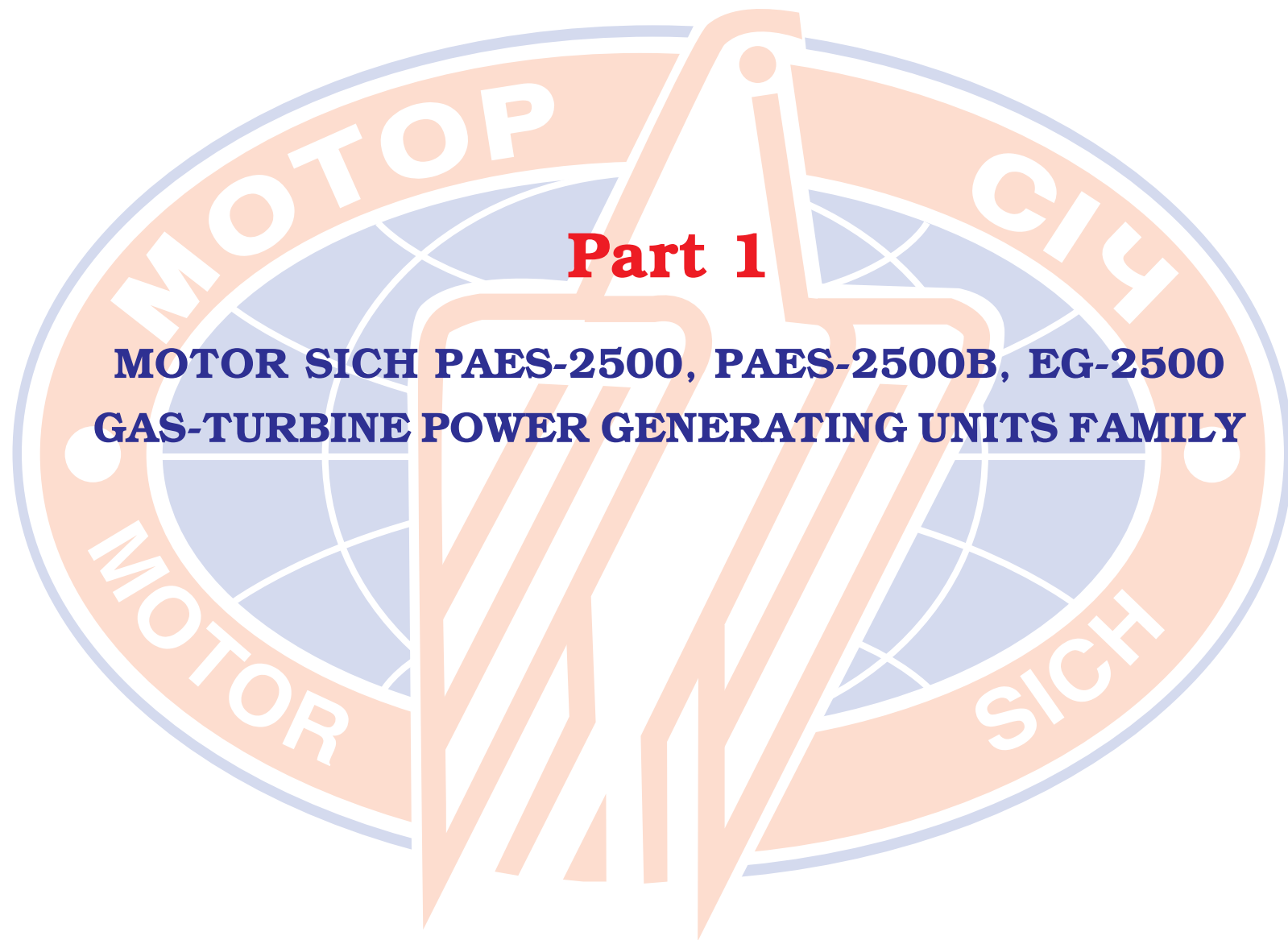

Part 1

**MOTOR SICH PAES-2500, PAES-2500B, EG-2500
GAS-TURBINE POWER GENERATING UNITS FAMILY**

MOTOR SICH PAES-2500, PAES-2500B, EG-2500 GAS-TURBINE POWER GENERATING UNITS FAMILY



PAES-2500B
mobile, automated,
of tropical version,
 $f = 60$ Hz
Series production since 1989



Base modification PAES-2500
mobile, automated,
 $f = 50$ Hz
Series production since 1970



EG-2500
block-transportable modification,
automated,
 $f = 50$ Hz
Series production since 1993

PAES-2500
PAES-2500B
EG-2500

THE FAMILY OF GAS-TURBINE POWER GENERATING UNITS OF 2.5 MW POWER

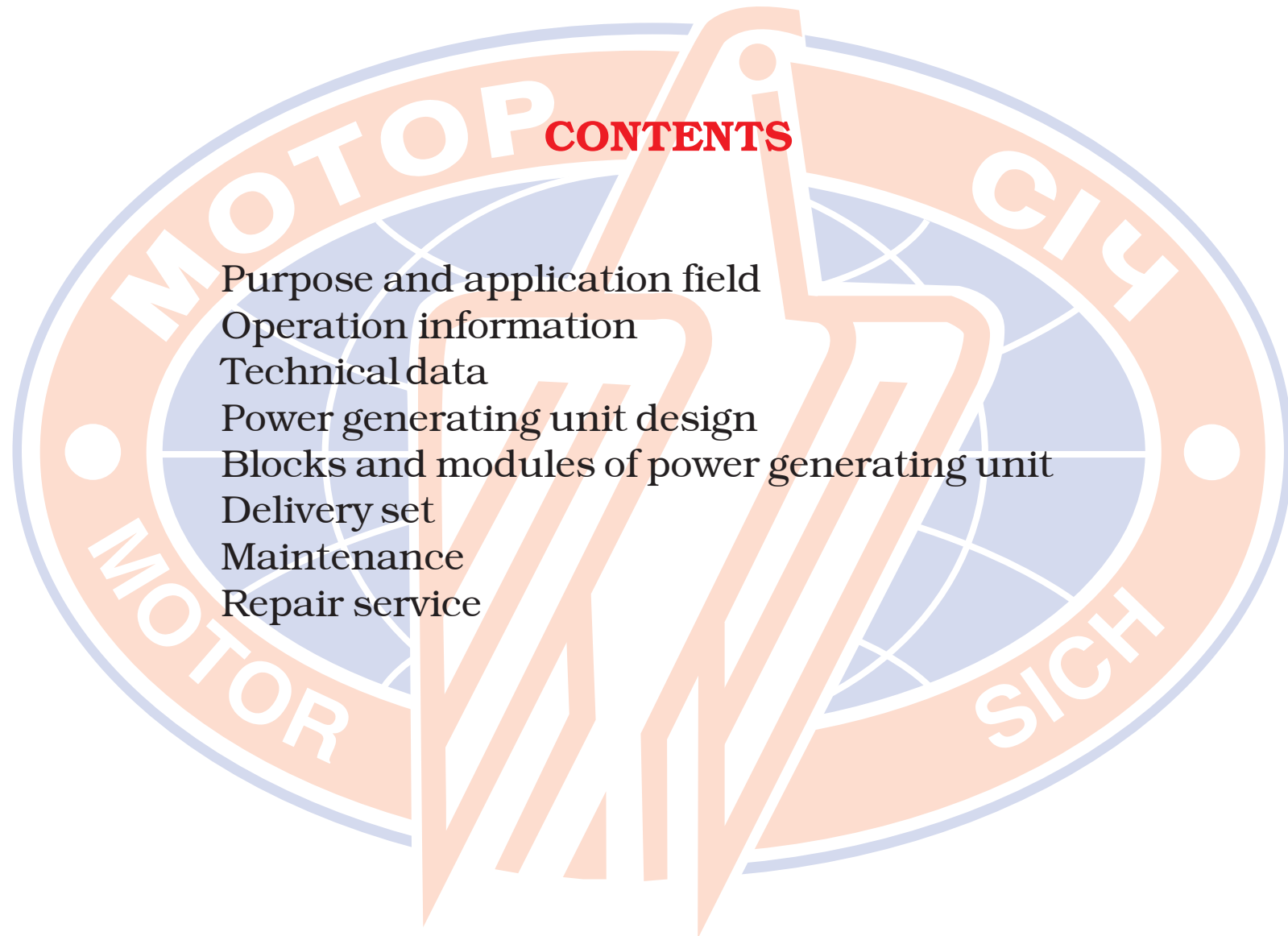

PAES-2500
PAES-2500B
EG-2500

PURPOSE AND APPLICATION FIELD

Gas-turbine power generating units of Motor Sich PAES-2500, PAES-2500B, EG-2500 type are intended to be used as the main electric power source for industrial and domestic consumers, in the absence of trunk power network, as well as the emergency power supply for the peak loads in the presence of trunk mains.

The power generating units can carry the independent load and operate in parallel with the system of any power, to do this they are stocked with all the necessary equipment.

The power generating units burn gaseous or liquid fuel.

More than 1500 power generating units are in operation in various climatic zones within the temperature range of -50 to $+55^{\circ}\text{C}$.

PAES-2500
PAES-2500B
EG-2500

TECHNICAL DATA

Operating characteristics	MOTOR SICH	PAES-2500	PAES-2500B	EG-2500
Power, kW:				
rated power		2500	2500	2500
maximum power		2750	2750	2750
Current		alternating, three-phase		
Voltage, V		6300	13800	6300 (13800)
Frequency, Hz		50	60	50 (60)
Power factor		0.8	0.8	0.8
Engine effective efficiency		0.24	0.24	0.24
Fuel		natural or casing-head gas, diesel fuel, kerosene		
Overall dimensions, mm:				
length		11565	11565	17600
width		2500	2500	2500
height		3700	3700	4250
Mass, kg		28500	28500	34500

ELECTRICAL ENERGY QUALITY INDICES

In the steady state thermal condition at the invariable balanced load:

the steady state voltage deviation, % ± 1
the steady state frequency deviation, % ± 1

At 50 % shedding/surging of the load:

transient voltage deviation, % ± 6
transient frequency deviation, % ± 7

The duration of transient process of restoring the frequency and voltage
(over the preset range) at 50 % shedding/surging of the load,
s, not more than 5

PAES-2500
PAES-2500B
EG-2500

CHARACTERISTICS

Power versus altitude above sea level
at air temperature of 15°C

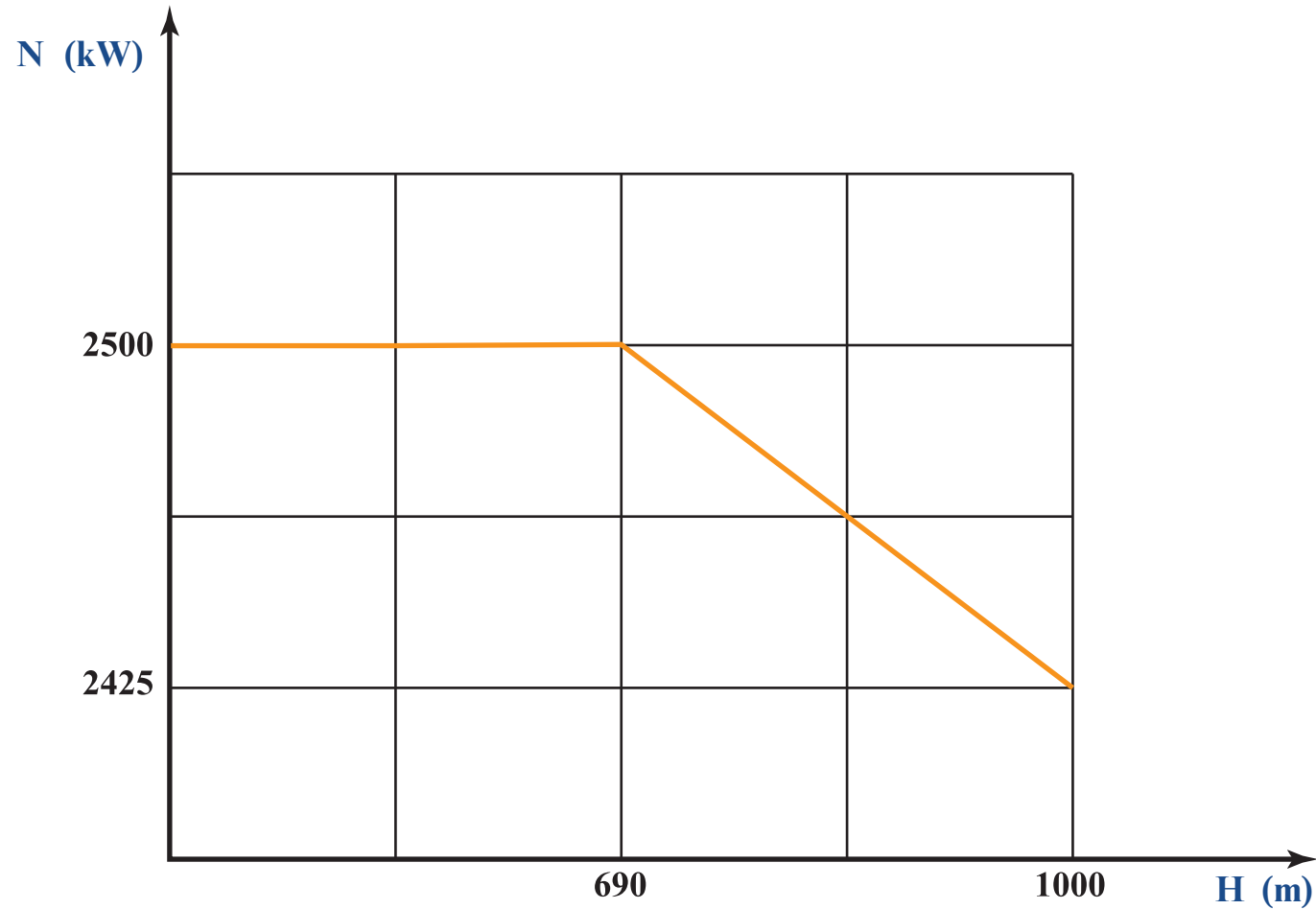

Metres	Feet
690	2264
1000	3281

N (kW)	hp
2425	3252
2500	3353

PAES-2500
PAES-2500B
EG-2500

CHARACTERISTICS

Power versus temperature at pressure of 96 kPa (PSI-14.7)

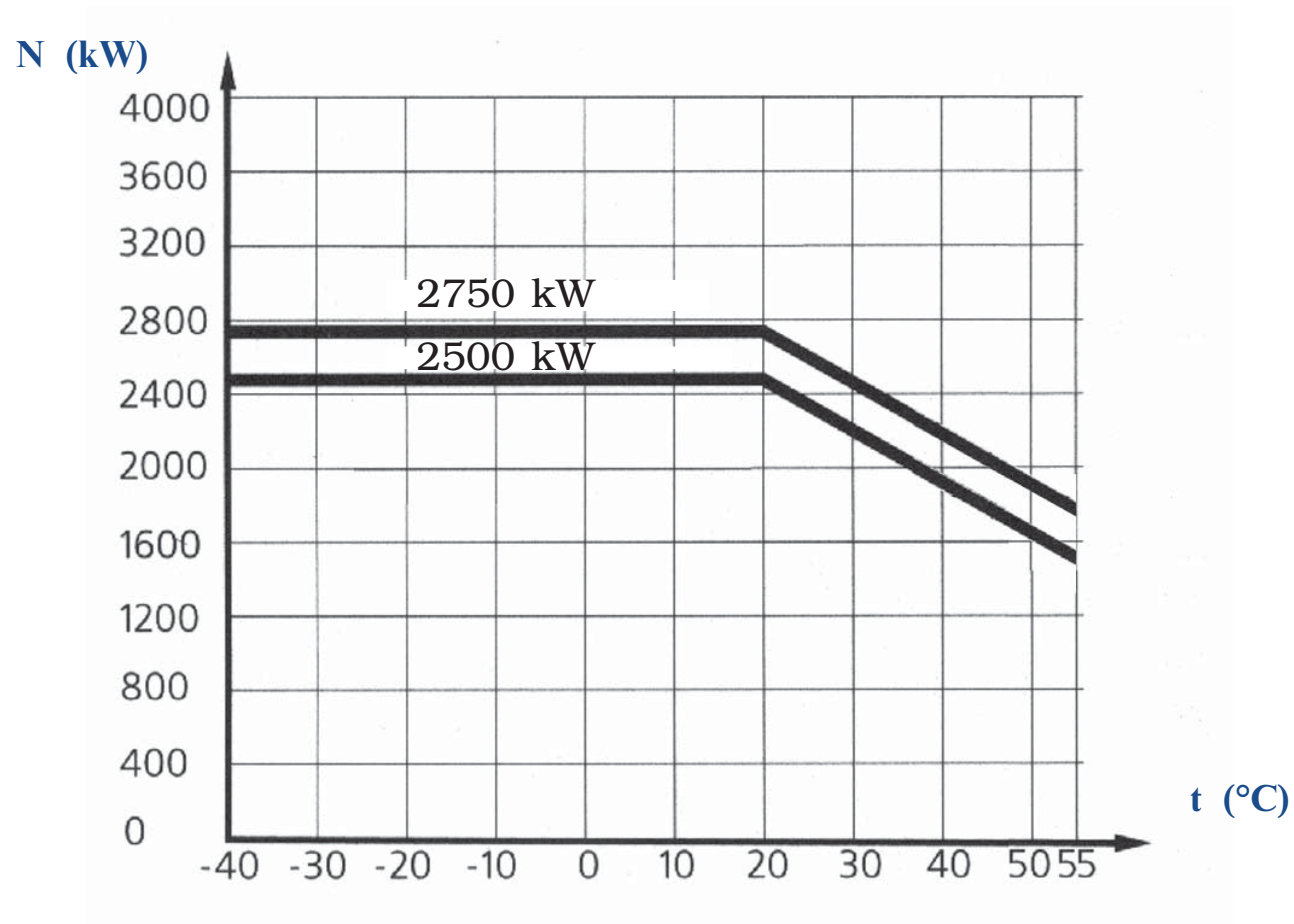

PAES-2500
PAES-2500B
EG-2500

CHARACTERISTICS

Gaseous fuel flow rate versus output shaft power
(lower fuel calorific value of 50000 kJ/kg, ISA)

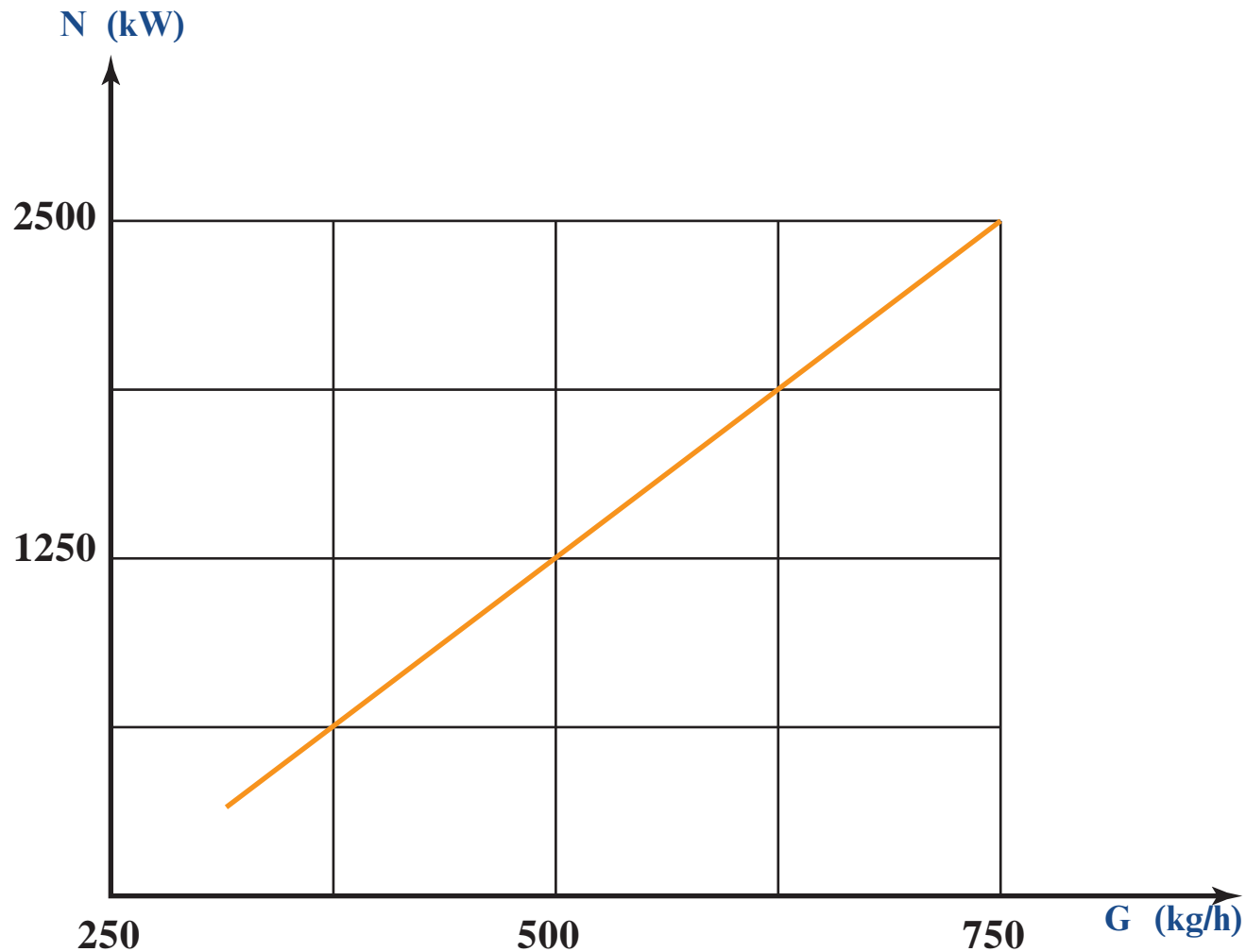

N (kW)	hp
1250	1676
2500	3353

ECOLOGICAL INDICES

The equivalent noise level at 1 m distance from the power generating unit contour does not exceed 85 dB (A).

The content of noxious substances in exhaust gases when operating at the rated load equals:

Ecological parameter	AI-20DME and AI-20DMECh (gaseous fuel)	AI-20DMN and AI-20DMNCh (liquid fuel)
Nitrogen oxides, NO _x , 15 % O ₂	91 mg/m ³ (44.4 ppm)	141 mg/m ³ (68.8 ppm)
Carbon oxide, CO, 15 % O ₂	107 mg/m ³ (85.6 ppm)	215 mg/m ³ (172 ppm)

PAES-2500
PAES-2500B
EG-2500

RELIABILITY INDICES

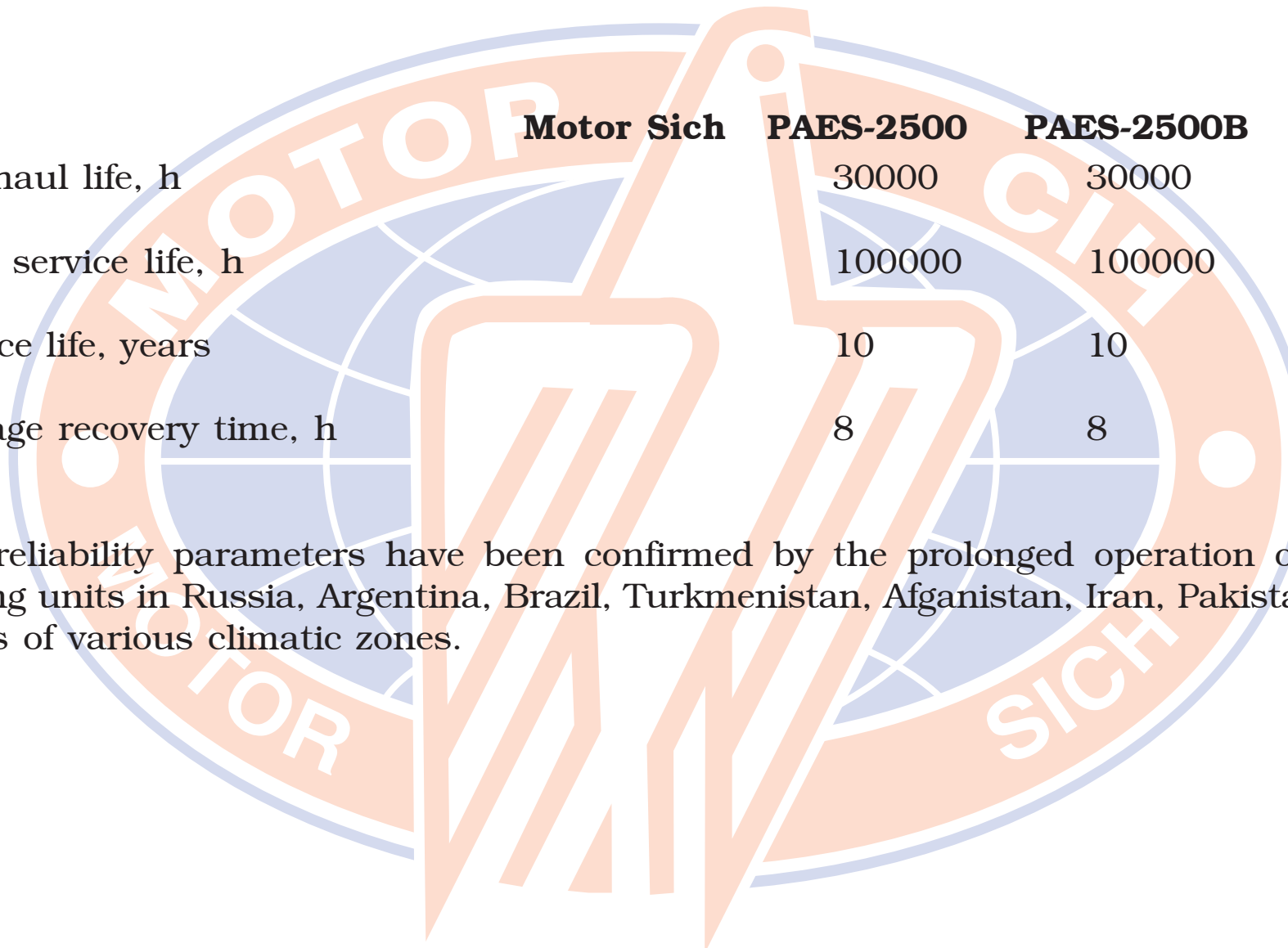

	Motor Sich	PAES-2500	PAES-2500B	EG-2500
Overhaul life, h		30000	30000	30000
Total service life, h		100000	100000	100000
Service life, years		10	10	10
Average recovery time, h		8	8	8

The reliability parameters have been confirmed by the prolonged operation of the power generating units in Russia, Argentina, Brazil, Turkmenistan, Afganistan, Iran, Pakistan and other countries of various climatic zones.

PAES-2500
PAES-2500B

POWER GENERATING UNIT DESIGN



Mobile automated power generating unit with the equipment is arranged in a special two-axle semitrailer OdAZ-99871. The power generating unit is transported to the operation site by a truck tractor being able to tow a semitrailer of 28 t total mass.

Semitrailer-van possesses supporting platforms and openings to mount the power generating units on a foundation and is provided with special jacks allowing to carry out levelling of a power generating unit on the platform prepared.

The noise suppressors at the inlet and exhaust sides are transported separately and mounted on the operating site.

The active noise suppressors are of:
a bar type — at the engine inlet;
a two-step plate type — at the engine outlet.

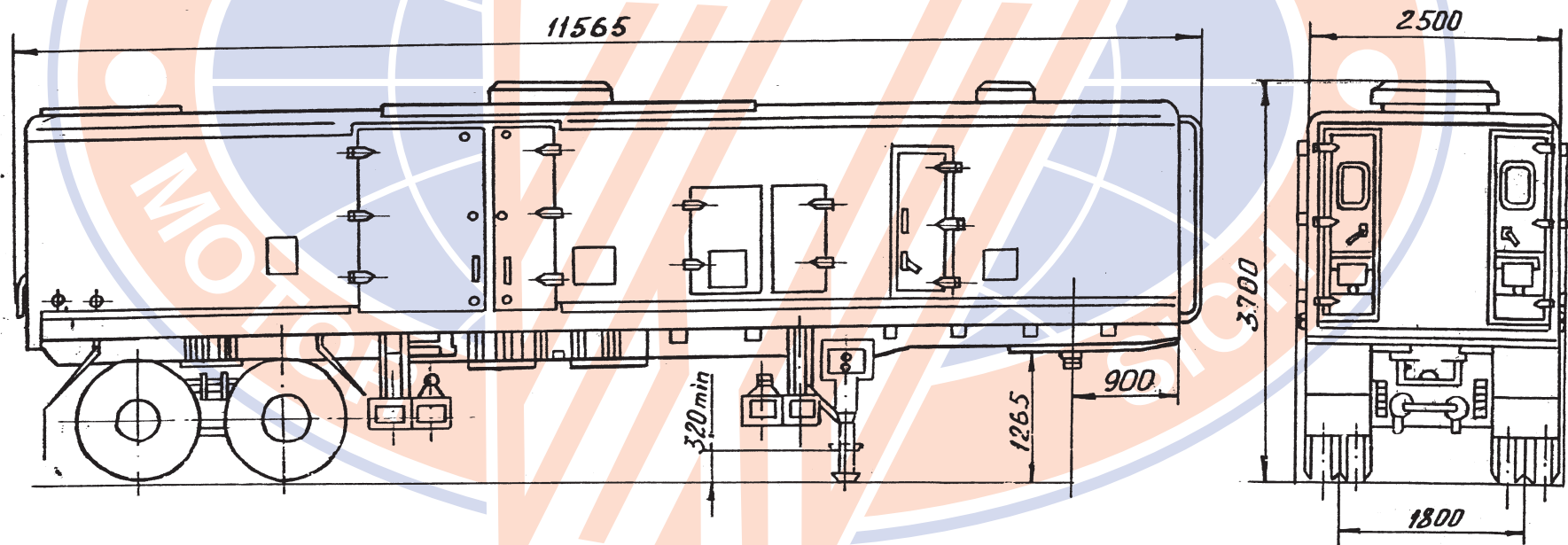

MOTOR SICH PAES-2500 (overall dimensions)

PAES-2500
PAES-2500B

MOTOR SICH PAES-2500 WITH NOISE SUPPRESSORS

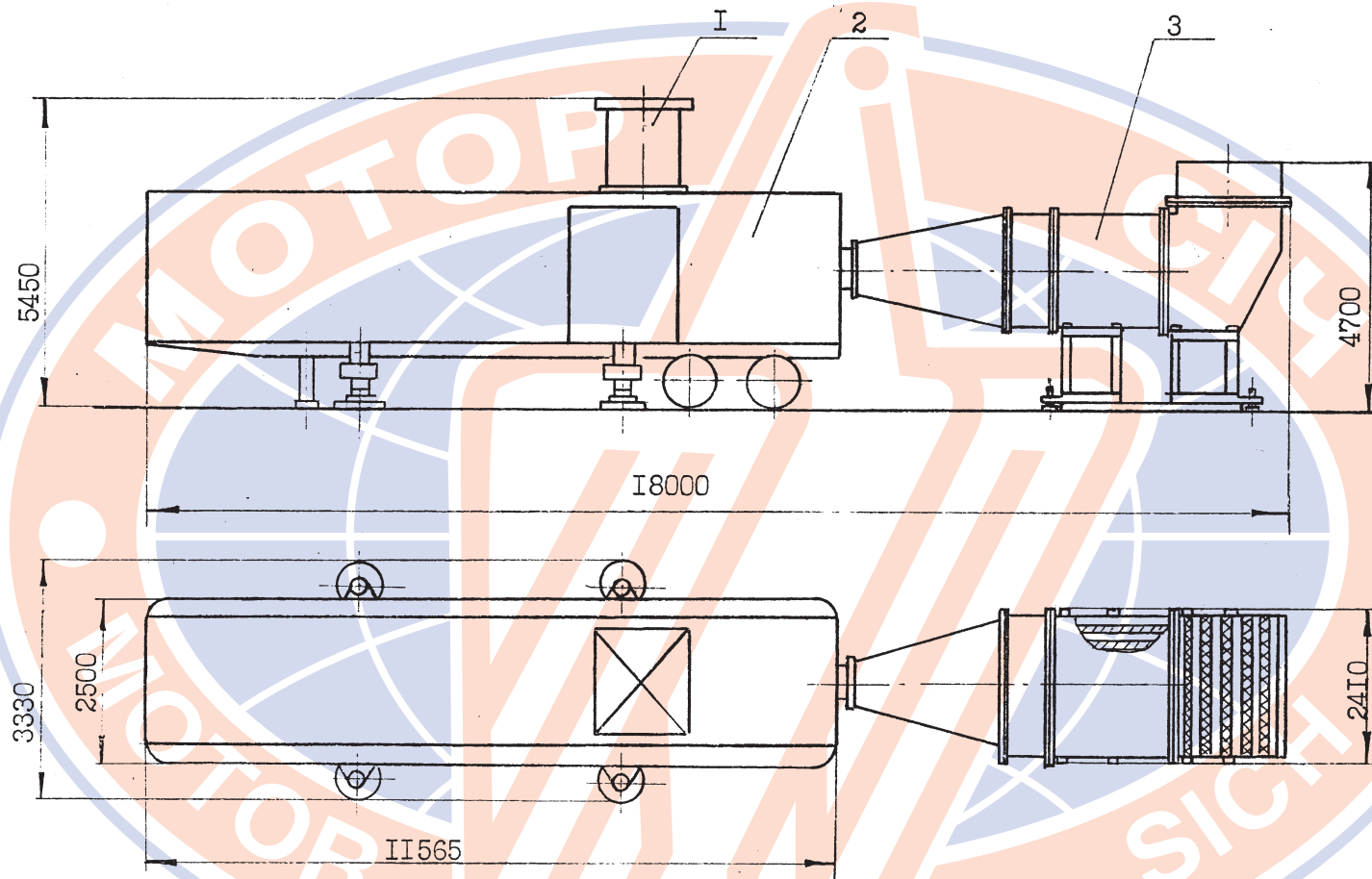

1. Noise suppressor at the gas-turbine engine inlet;
2. PAES-2500 power generating unit;
3. Noise suppressor at the gas-turbine engine exhaust side.

EQUIPMENT ARRANGEMENT

The semitrailer-van is divided into the operator's room and engine compartment with the help of a dismantlable partition complete with a sliding door.

A control panel and high voltage distributing device are located in the operator's room.

Engine, generator and all the systems providing the engine start and its operation under all load conditions as well as a panel to control the generator excitation are installed in the engine compartment.

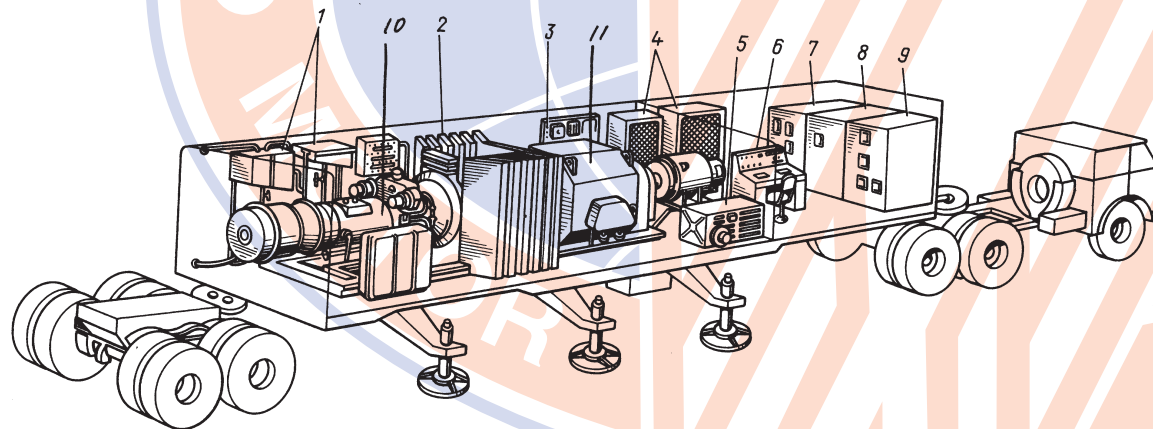

1. Fuel-oil block
2. Noise suppressor
3. Starting system panel
4. Generator control cabinets
5. Starting unit
6. Control panel
7. Relays cabinet
8. High-voltage circuit breaker cabinet
9. Transformer cabinet
10. Engine
11. Generator

Block-transportable power generating unit. The entire equipment is arranged in two containers. The inlet noise suppressor is incorporated in the container of turbogenerator. The two-stage exhaust noise suppressor is installed at the engine exhaust side.

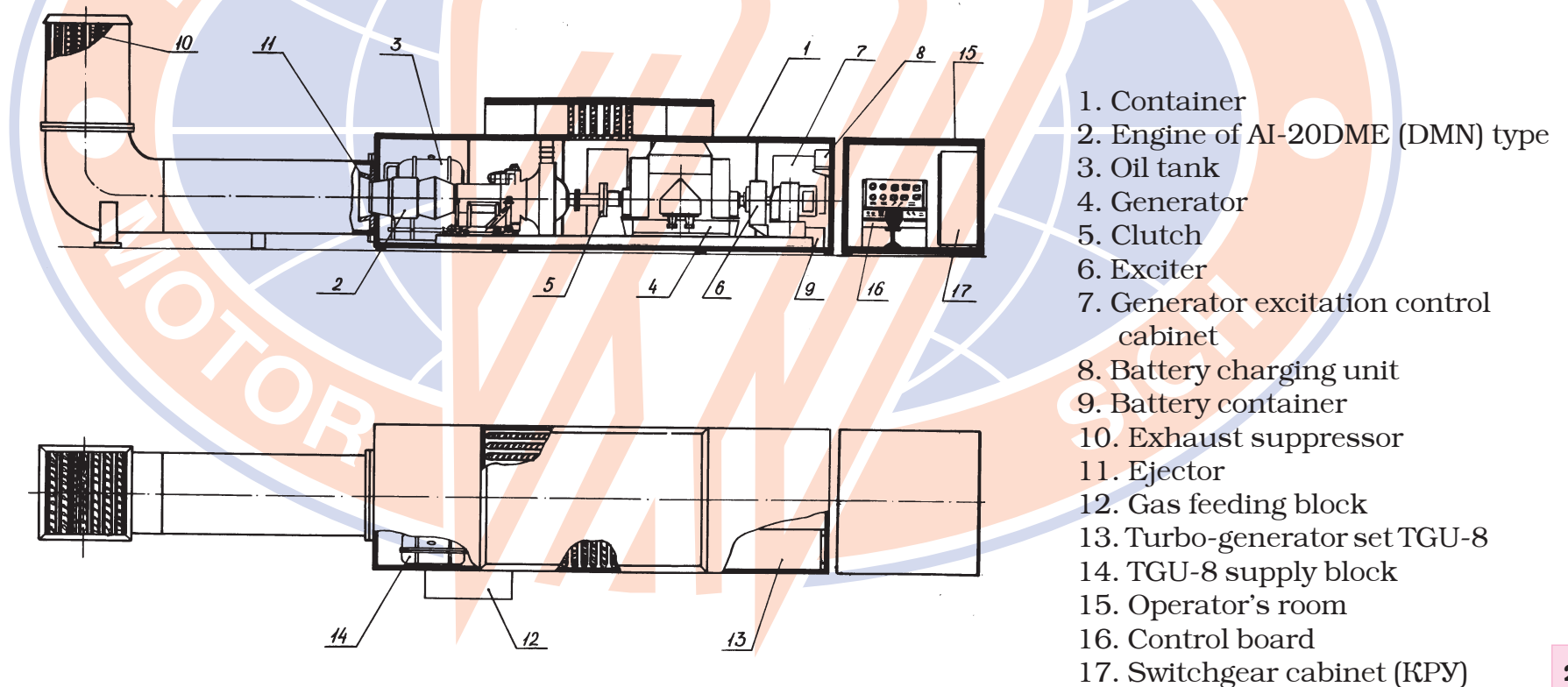

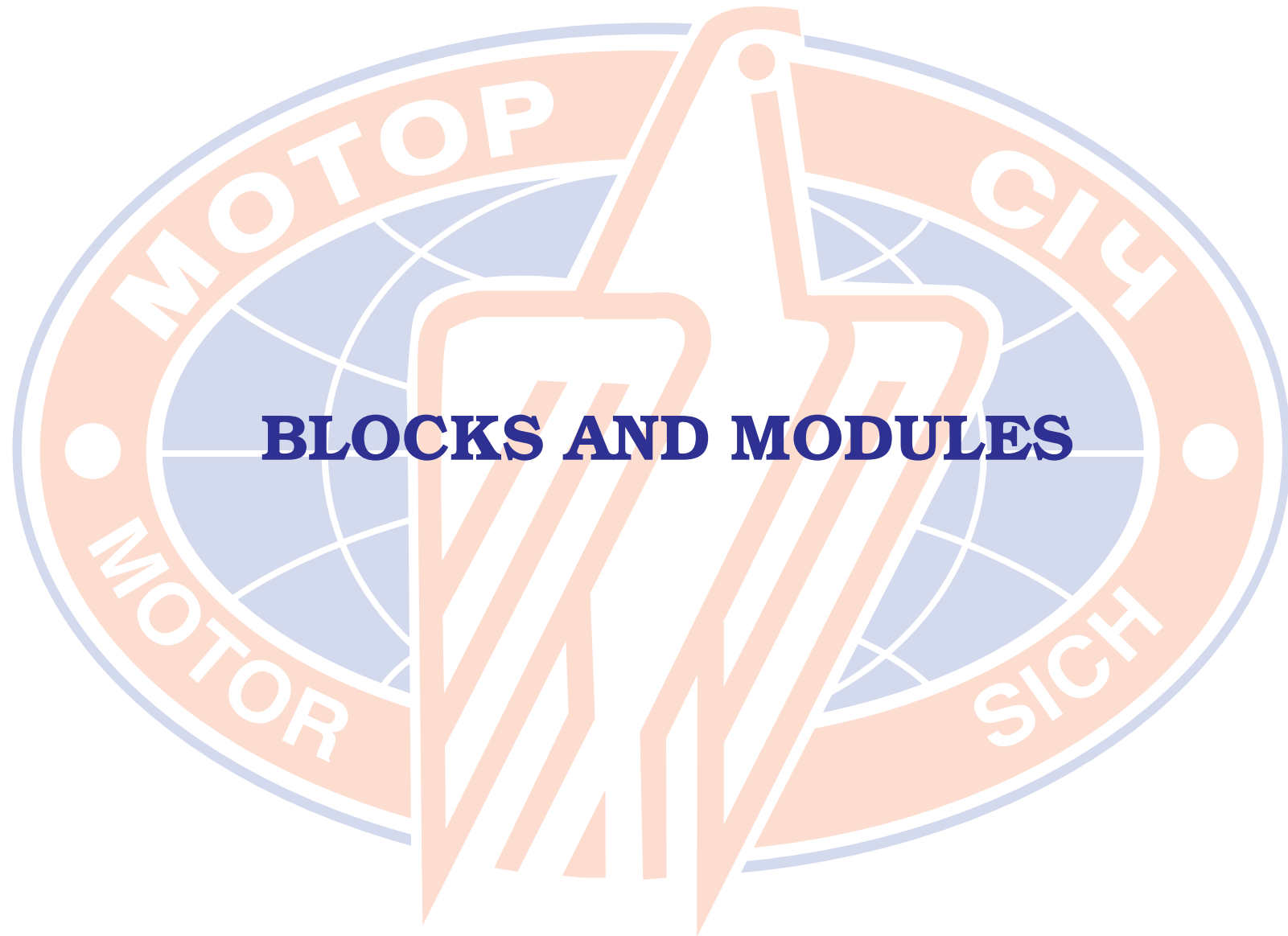

BLOCKS AND MODULES

PAES-2500
PAES-2500B
EG-2500

TURBOGENERATOR PLANT TGU-8

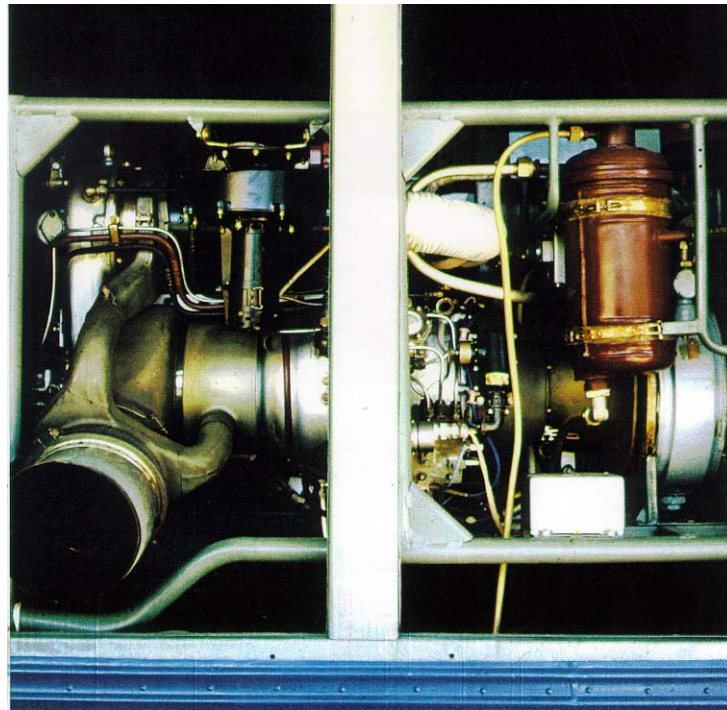

The turbogenerator plant is mounted in the power generating unit container and serves for actuating the main gas turbine engine.

The above set may be used for feeding ancillary systems and recharging storage batteries.

TGU-8 is intended for starting the main engine of power generating unit.

TECHNICAL DATA

Maximum power conditions of turbogenerator (when starting the main engine):

Power across ΓC-24A generator terminals, kW	60
Generator turbine rotational speed, min ⁻¹	26000
Exhaust gas temperature, °C	750

Short-time overload conditions:

Power across ΓC-24A generator terminals, kW	82
Exhaust gas temperature, °C	780

Continuous operation conditions:

Power across ΓC-24A generator terminals, kW	14
Exhaust gas temperature, °C	750

Synchronous alternating three-phase current generator operates at 50 Hz and is cooled by self-ventilation. The generator set incorporates the generator excitation control cabinets.

TECHNICAL DATA

Rated power, kW/kV·A	2500/3125
Rated voltage, V	6300
Frequency, Hz	50
Excitation current, A.....	287
Power factor	0.8
Rotor rotational speed, min ⁻¹	1000
Mass, kg.....	9440

SYNCHRONOUS GENERATOR HSPT710RF3

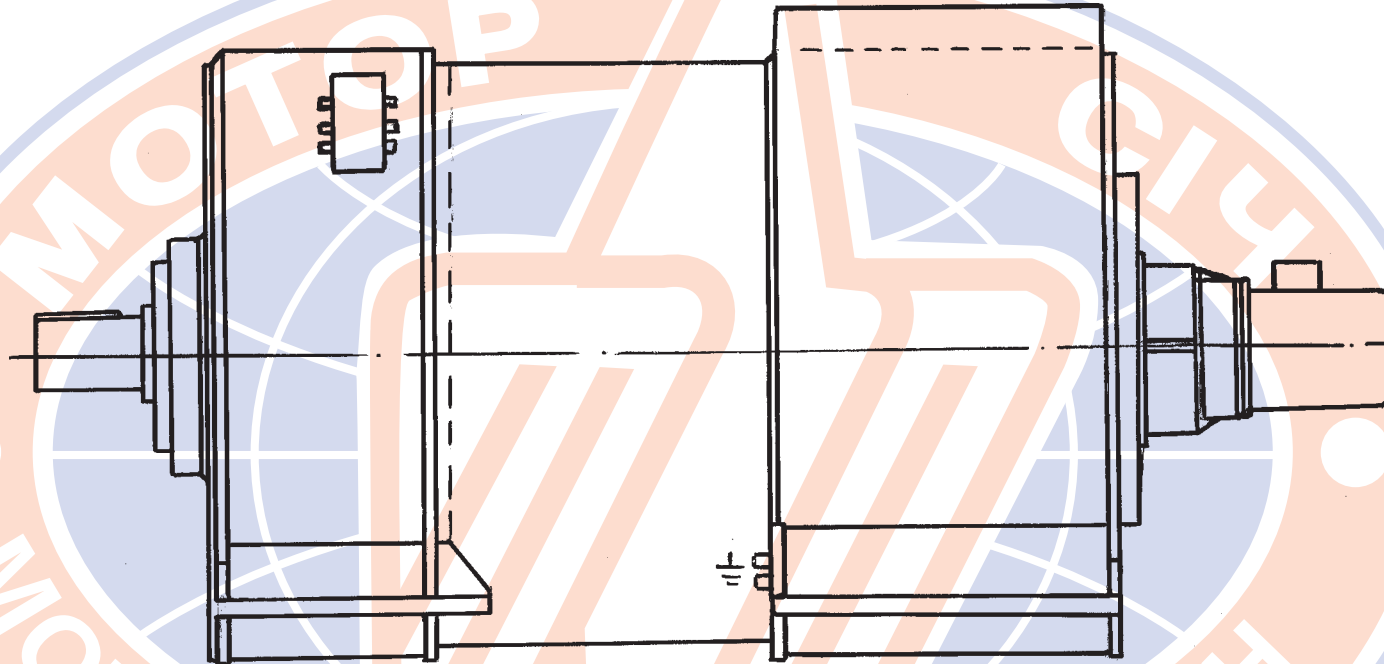

Synchronous three-phase generator is designed to produce alternating three-phase current of 60 Hz and provided with the gas-turbine engine drive.

The above generator is run under the conditions of self-ventilation and fitted with the brushless excitation system featuring an electronic excitation regulator.

TECHNICAL DATA



Rated power, kW/kV·A	2500/3125
Rated voltage, V	13800
Frequency, Hz	60
Current, A	131
Power factor	0.8
Rotor rotational speed, min ⁻¹	1200
Mass, kg	9250

The switchgear is intended to receive the electric power from the power generating unit generator and distribute it among the consumers.

The switchgear includes apparatus and devices ensuring the operation and protection of generator as well as the electric power distribution during independent and parallel operation.

TECHNICAL DATA

Rated voltage, V	6300
Max. operating voltage, V.....	7200
Rated current of switchgear cabinet, A	400
Rated current of circuit breaker, kA, not more than.....	20
Power transformer capacity, kV·A.....	25
Insulation level.....	light
Operating rated voltage, V	24
Total mass of switchgear cabinets, kg	2535

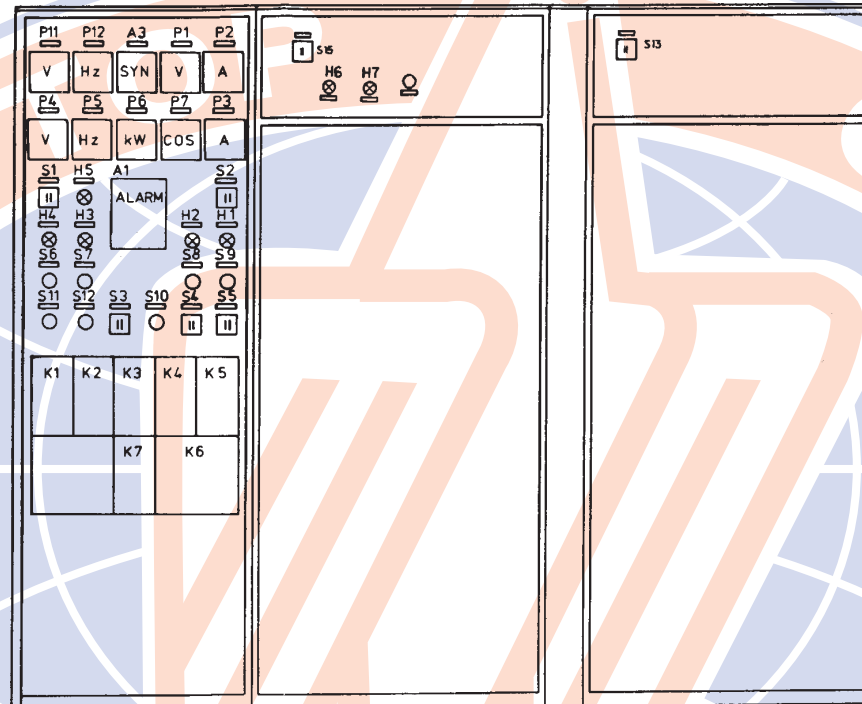

The switchgear is designed for receiving electric power from the power generating unit generator and distributing it among the consumers.

The high voltage switchgear comprises the apparatus and devices enabling operation and protection of the generator as well as distributing electric energy both under independent and parallel conditions of power generating unit operation.

TECHNICAL DATA

Rated voltage, V	13800
Maximum operating voltage, V	15000
Rated current of switchgear cabinet, A	630
Rated current of circuit breaker, not more than, kA	18
Power transformer capacity, kV·A	25
Insulation level	Γ
Control rated voltage, V	24
Total mass of switchgear cabinets, kg	1220

PAES-2500
EG-2500

CONTROL BOARD



The control board serves to control the main engine, turbo-generator plant TGU-8, high voltage equipment, ancillary systems, as well as to regulate parameters of electric power generating unit and its auxiliary systems.

The board is made as a separate unit and installed in the operator's room.

**PAES-2500
EG-2500**

MOTOR HEATER MP-70

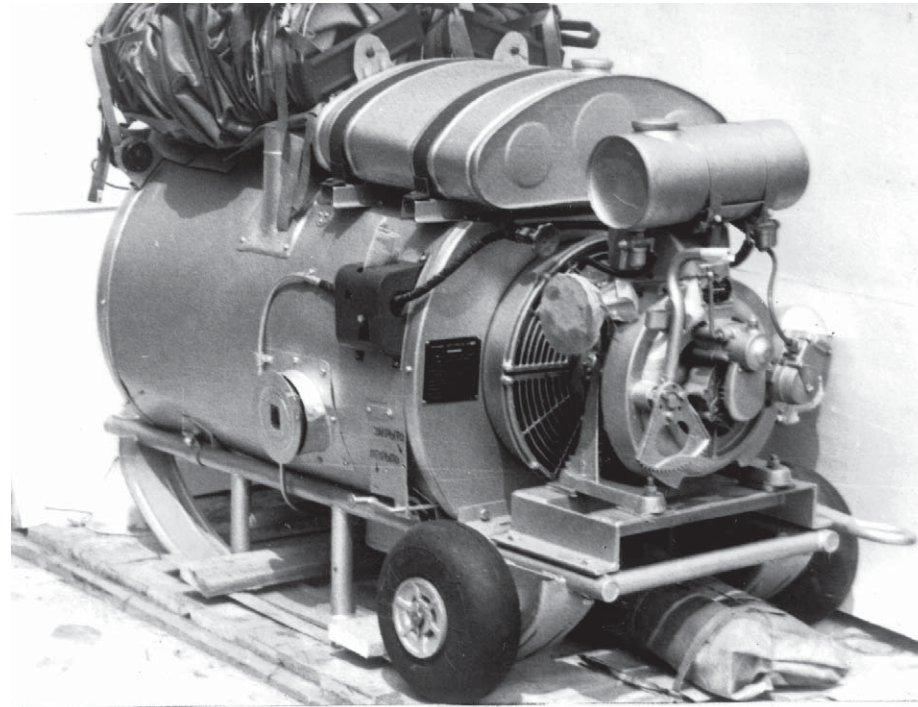

The heater is included into the delivery set and intended to preheat the power generating unit equipment before starting under the winter conditions of operation.

SYSTEMS PROVIDING POWER GENERATING UNIT OPERATION

The power generating unit is equipped with the following systems which are necessary for independent operation:

Lubricating and breathing system

Fuel supply system

Automatic control and monitoring system

Starting system

Cooling and ventilating system

Noise suppressing system

The systems of heating, electric power supply and others

The set includes:

The semitrailer-van with the whole power generating unit equipment

Engine inlet noise suppressor

Engine exhaust noise suppressor

Set of tools and devices for the technical servicing of the entire power generating unit equipment

Set of power generating unit spare parts including the spare parts for the entire power generating unit equipment

Set of operation and maintenance publications

The set includes the turbo-generator container complete with the inlet noise suppressor and the power generating unit facilities providing for the engine and generator operation;

Exhaust noise suppressor;

Operator's room with the cabinets for high voltage switchgear and control board;

Set of tools and appliances for servicing the entire power generating unit equipment;

Set of spare parts of the power generating unit equipment including spares for power generating unit equipment;

Set of operation and maintenance publications.

PAES-2500
PAES-2500B
EG-2500

TRANSPORTATION



The above power generating units are shipped by road, rail, water and air transport.
All cargo units are made according to the international standard clearance limits and are provided with mooring devices.

MANUFACTURER'S SERVICE IS REPRESENTED BY:

- in-time delivery of the blocks and accessories instead of those which completed their service life;
- operation servicing on the 'on condition' basis;
- theoretical and practical training of customer's specialists at the manufacturing plant or under the field conditions at any point of the world; the information obtained by the customer's specialists prevents from making mistakes when servicing our equipment;
- providing a spare engine to the customer to ensure the continuous functioning of the power generating unit during overhaul of the customer's engine.
- sending manufacturer's specialists to the customer for the time of power generating unit starting and, if necessary, for any time of operation.

LOW OPERATION EXPENSES DUE TO:

- minimum capital expenditure for the operating site, fuel supply, electric energy reception;
- low cost maintenance;
- power self-supplying;
- long service life;
- high operation reliability;
- insignificant irretrievable oil losses;
- high level of equipment serviceability

HIGH SERVICEABILITY DUE TO:

- an easy access to the places of checking and adjustment;
- remote monitoring and diagnosis of the power generating unit equipment condition;
- a speedy trouble eliminating through availability of necessary tooling and appropriate spare parts set.

REPAIR SERVICING

- is supervised by the manufacturer
- the manufacturer provides for supply of the appropriate blocks and other equipment items for the running repair
- anticipates that the engine overhaul is performed at the manufacturing plant after which the original overhaul life is assigned
- proceeds from the manufacturer's willingness to cooperate with the companies which wish to create their own repair facilities

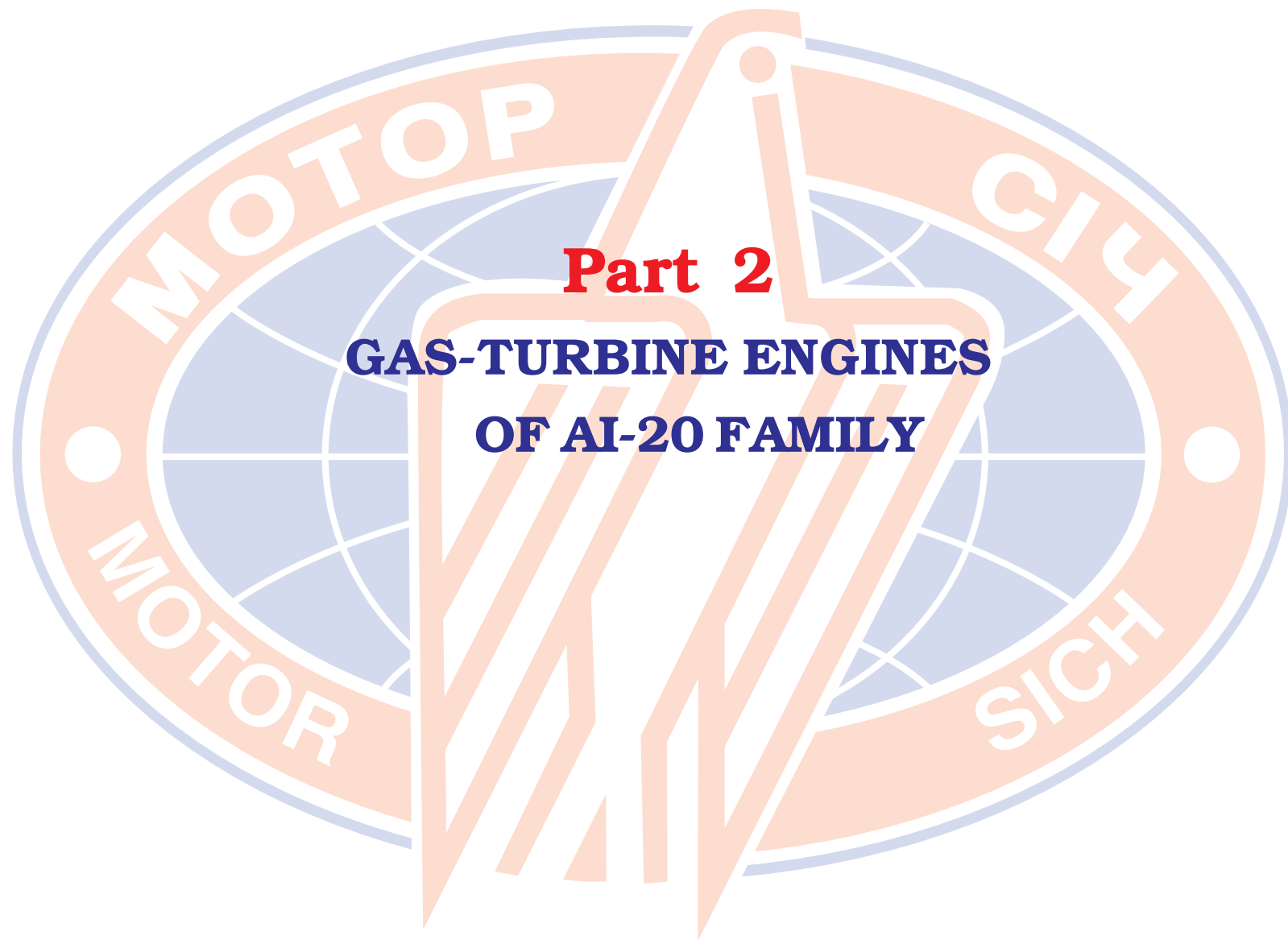

Part 2

GAS-TURBINE ENGINES OF AI-20 FAMILY

GAS-TURBINE ENGINES OF AI-20 FAMILY

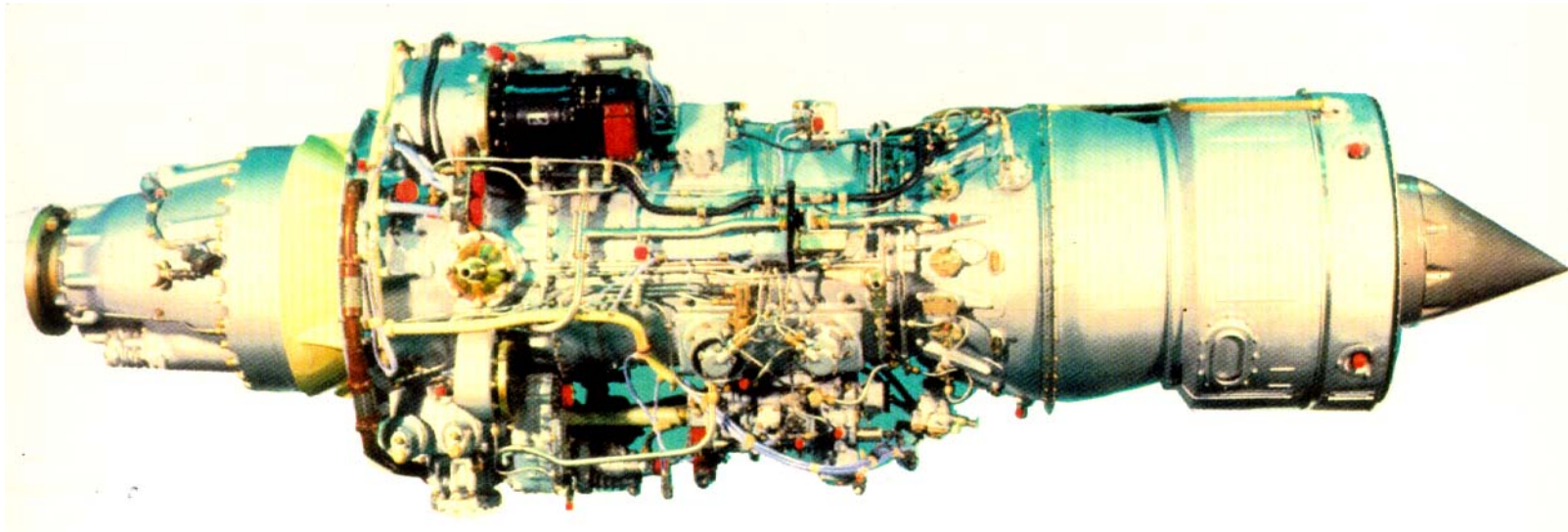

AI-20 engine

AI-20DMN
 AI-20DME
 AI-20DMNCh
 AI-20DMECh

GAS-TURBINE ENGINES OF AI-20 FAMILY

**ENGINE FAMILY
 TO DRIVE POWER GENERATING UNIT GENERATOR
 OF 2.5 MW POWER AND CURRENT FREQUENCY OF:**

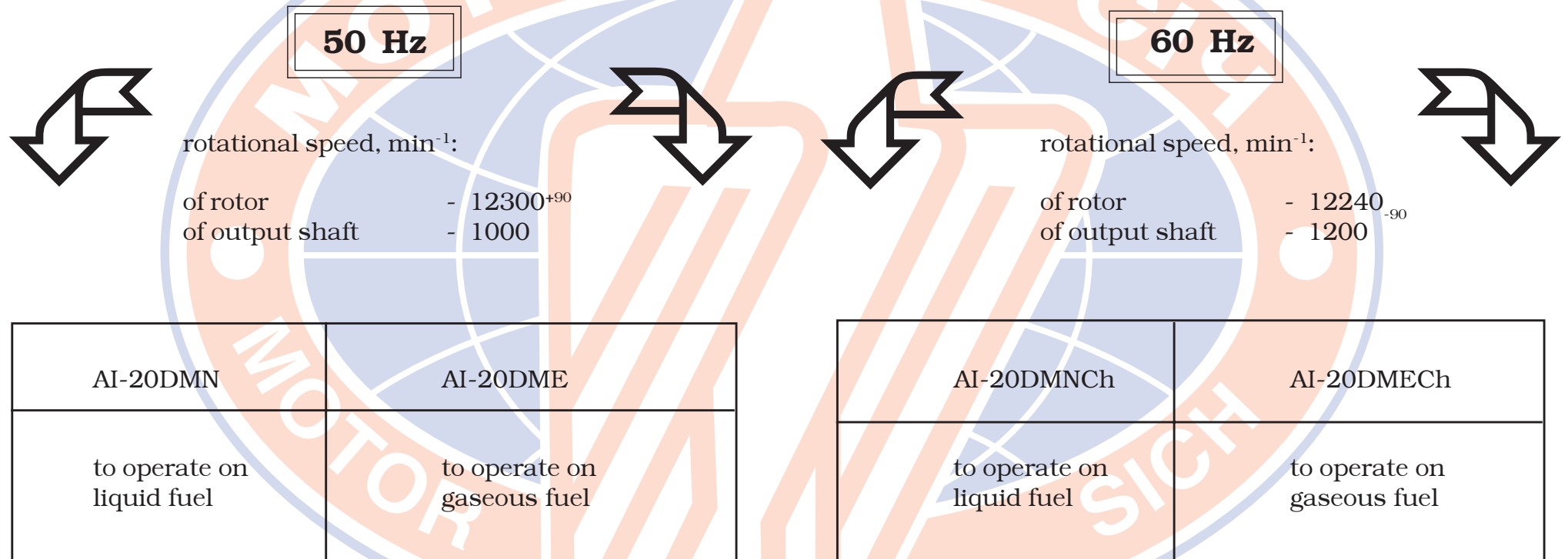

GAS-TURBINE ENGINES OF AI-20 FAMILY

TECHNICAL CHARACTERISTICS

INDICES	AI-20DMN AI-20DMNCh	AI-20DME AI-20DMECh
Engine type	gas-turbine	
Version	general climatic	
Fuel type	kerosene, diesel fuel	natural or casing-head gas
Lubrication type	circulating, forced-feed	
Power at engine operation conditions depending on power generating unit generator load, kW: — idle power condition — 0.5 nominal — nominal — overload	<div style="display: flex; justify-content: space-around; align-items: center;"> <div style="text-align: center;">0</div> <div style="text-align: center;">1250</div> <div style="text-align: center;">2500</div> <div style="text-align: center;">2750</div> </div>	
Fuel consumption at nominal conditions, kg/h, not more than	995	836
Specific fuel consumption at nominal conditions, kg/kW·h, not more than	0.398	0.334

AI-20DMN
AI-20DME
AI-20DMNCh
AI-20DMECh

GAS-TURBINE ENGINES OF AI-20 FAMILY

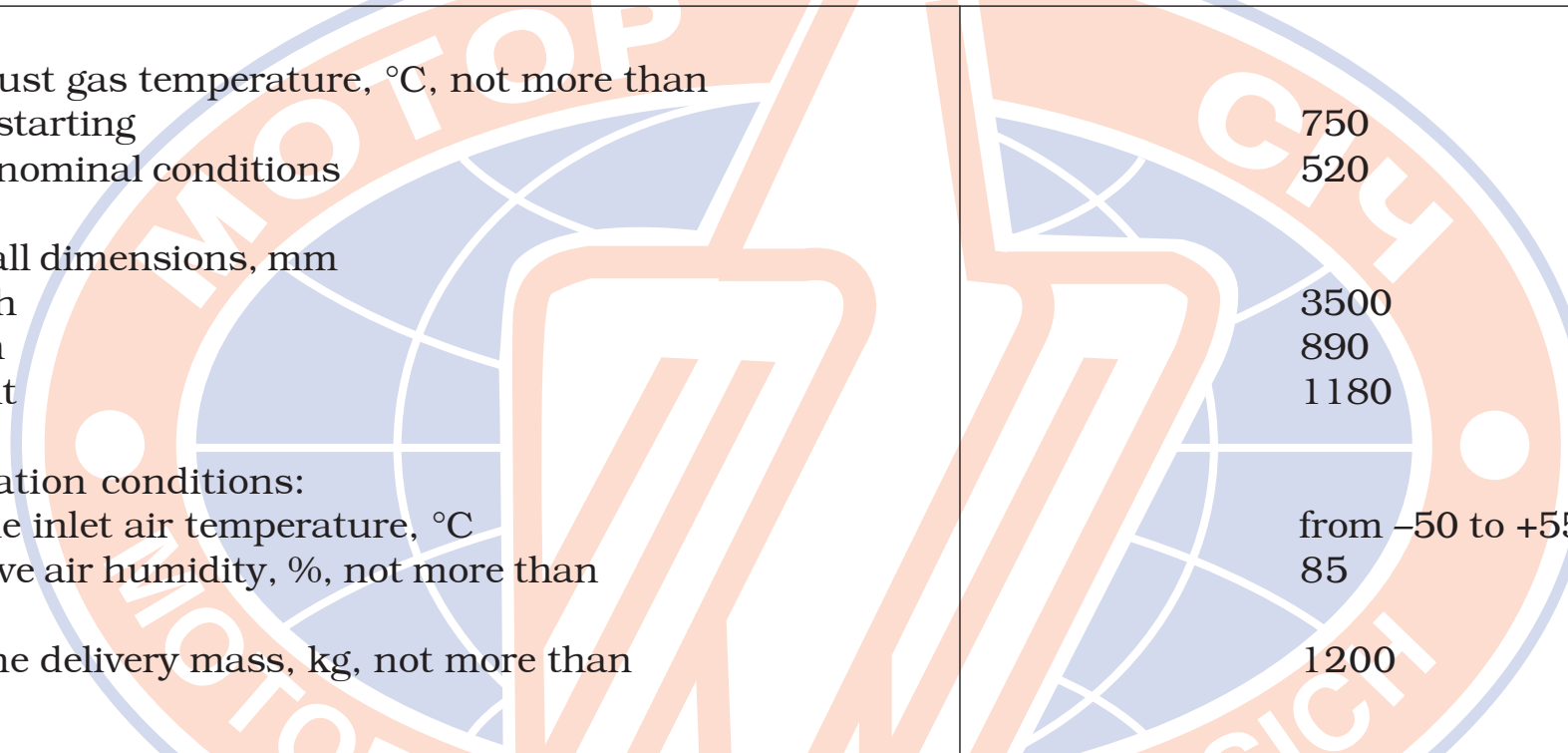

Exhaust gas temperature, °C, not more than	
— at starting	750
— at nominal conditions	520
Overall dimensions, mm	
length	3500
width	890
height	1180
Operation conditions:	
engine inlet air temperature, °C	from -50 to +55°
relative air humidity, %, not more than	85
Engine delivery mass, kg, not more than	1200

GAS-TURBINE ENGINES OF AI-20 FAMILY

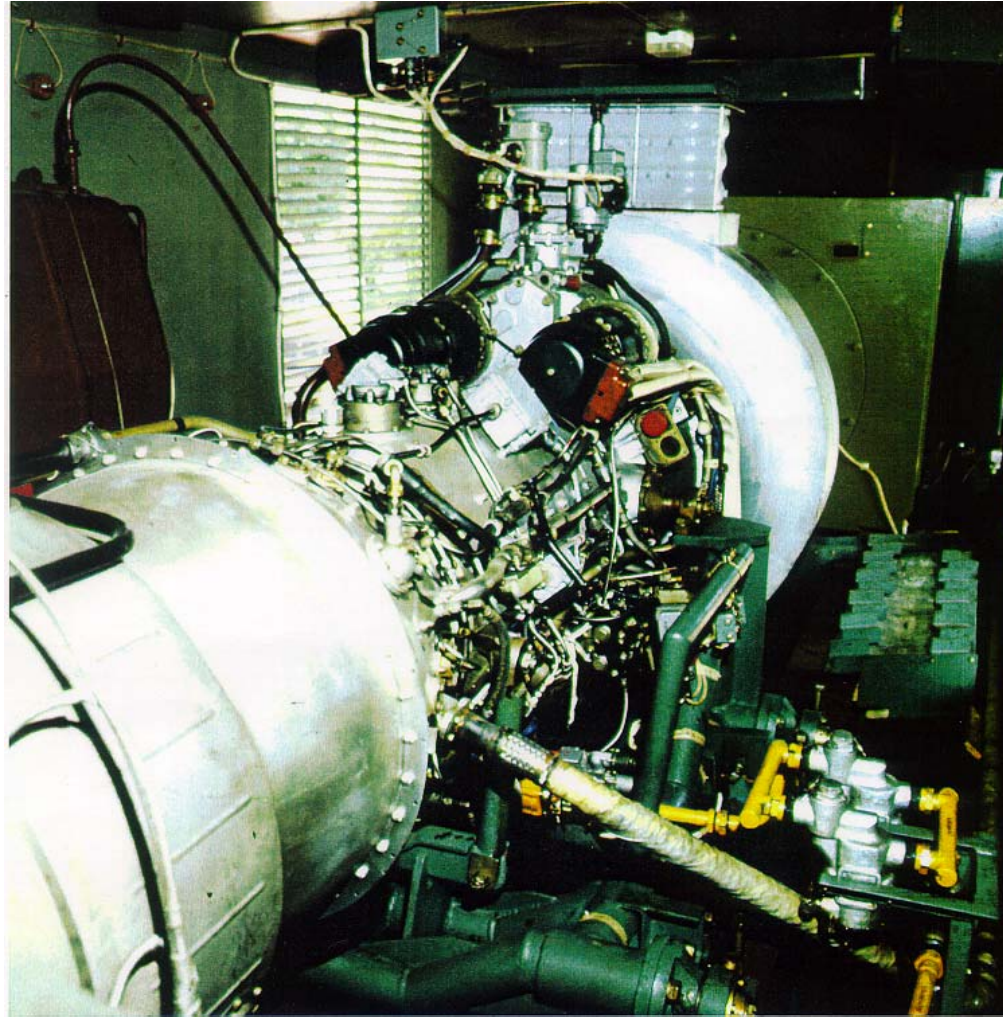

Drive engine external view

AI-20DMN
AI-20DME
AI-20DMNCh
AI-20DMECh

GAS-TURBINE ENGINES OF AI-20 FAMILY

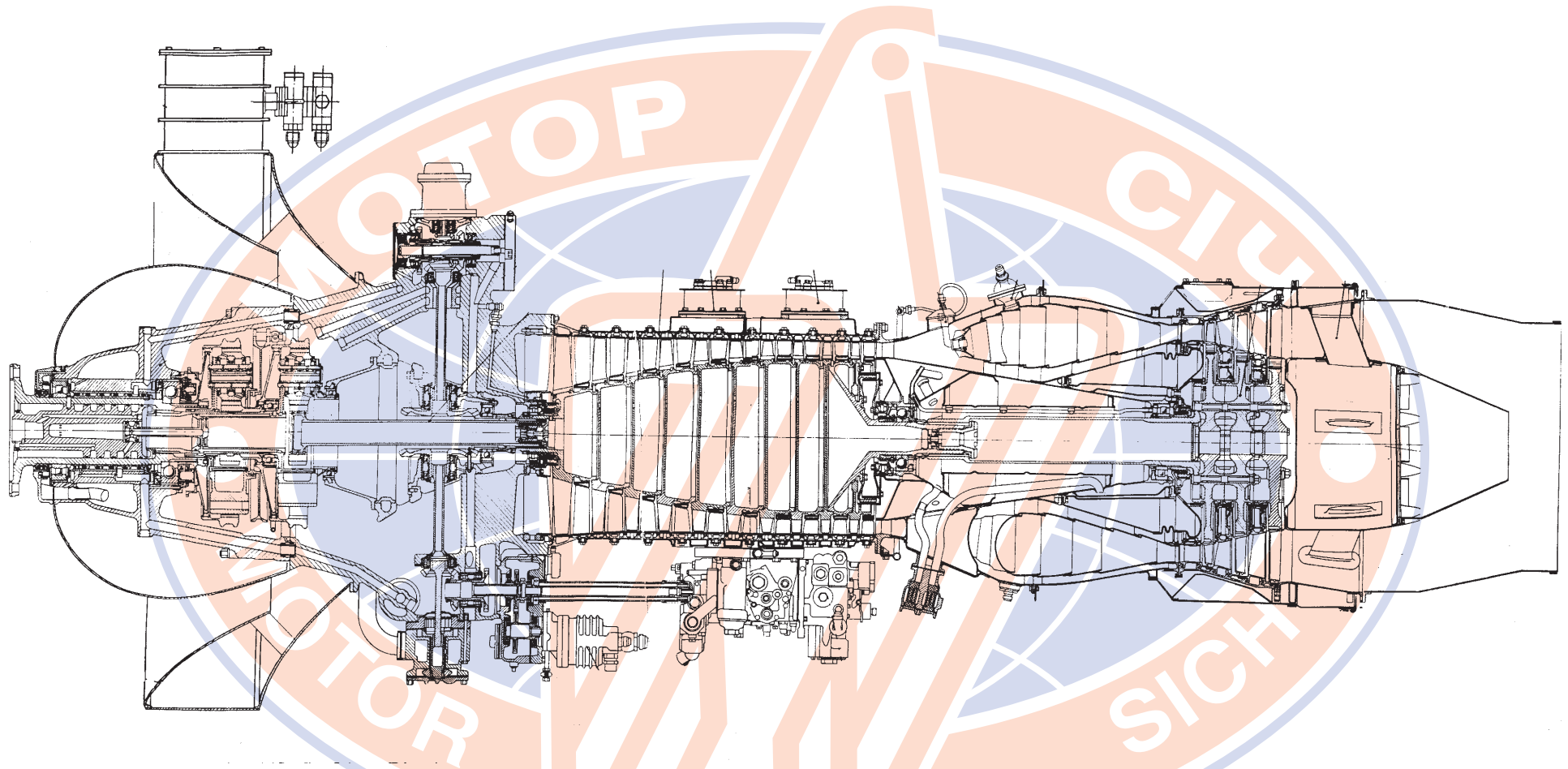

Longitudinal section of drive engine

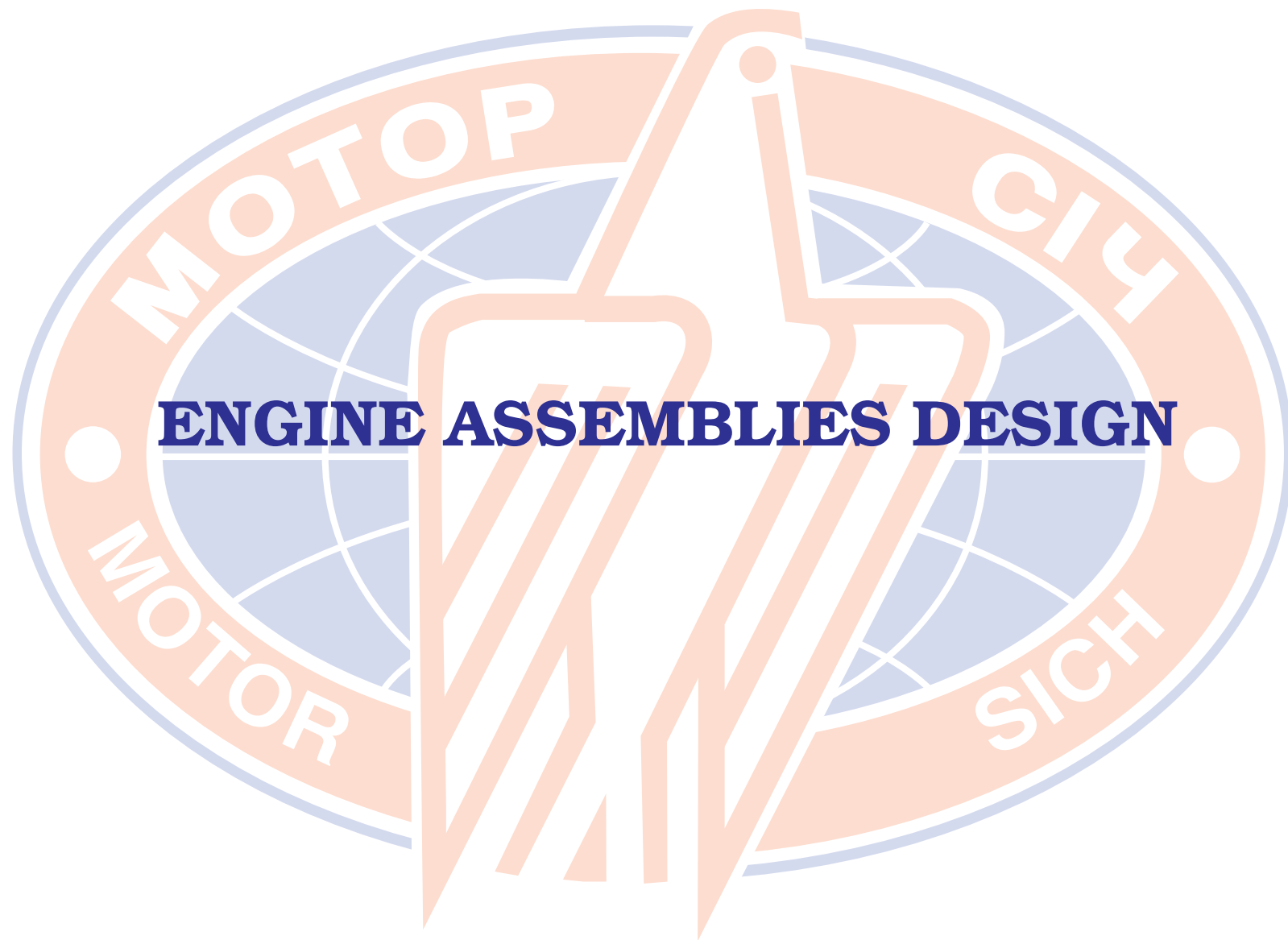

ENGINE ASSEMBLIES DESIGN

REDUCTION GEAR

The gear, located in the front part of the engine, is intended to reduce the number of engine rotor revolutions and transfer the gas turbine excess power to the rotating shaft of synchronous generator.

The gear consists of a planetary stage, a gear train stage, an output shaft and a torquemeter mounted in the reduction gear casing cast of magnesium alloy.

The engine rotor is coupled to the reduction gear mechanism by means of a drive shaft.

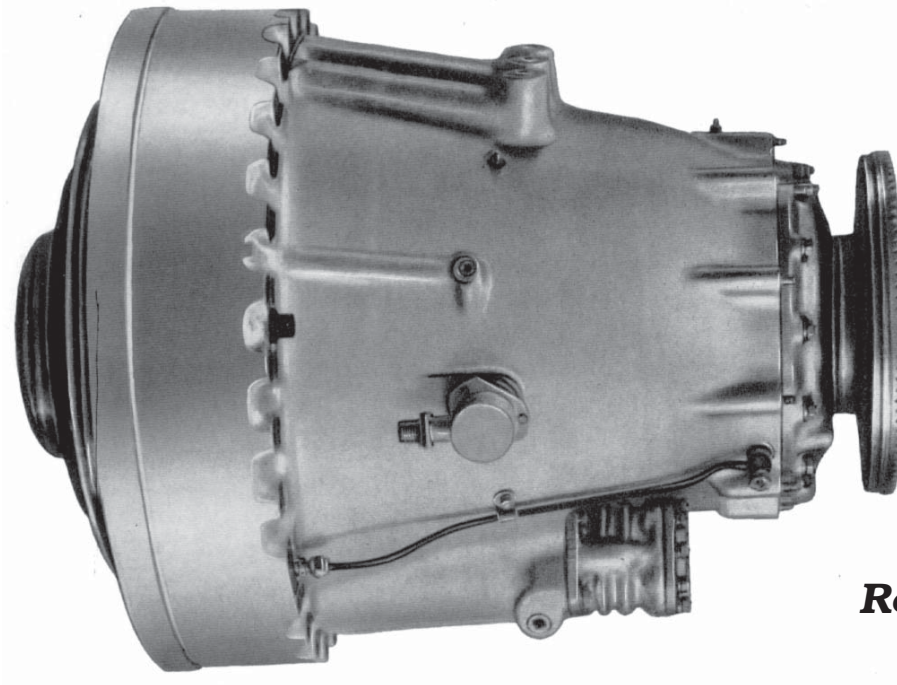

Reduction gear assembly

FRONT CASING

The casing serves for the power coupling of the compressor with the engine reduction gear.

The accessories of the main engine systems and engine-to-engine mount attachment trunnions are attached to the flanges located on the exterior surface of the casing.

The drives of accessories, compressor rotor front bearing support and inlet guide vanes assembly are mounted in the front casing chambers.

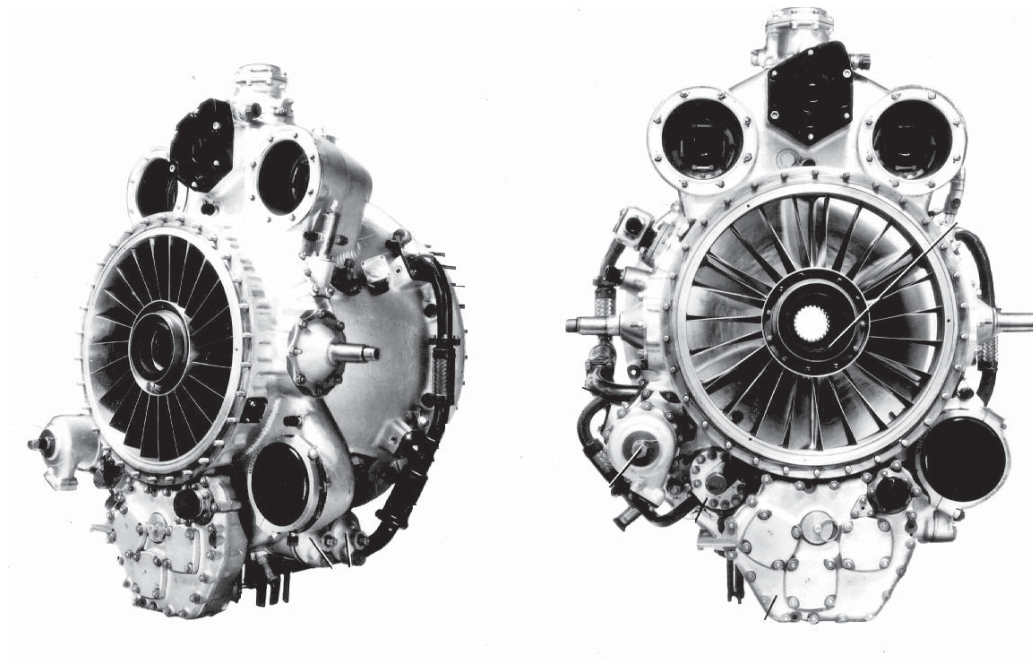

Front casing

COMPRESSOR

The axial-flow subsonic ten-stage compressor is intended to suck in, compress and deliver the air into the combustion chamber.

The drum-and-disk type compressor rotor consists of ten separate disks with the blades fitted to their rims.

Disks, rear shaft and compressor rotor blades are made of high quality stainless steel.

The compressor casing is a welded structure with a split in the horizontal plane.

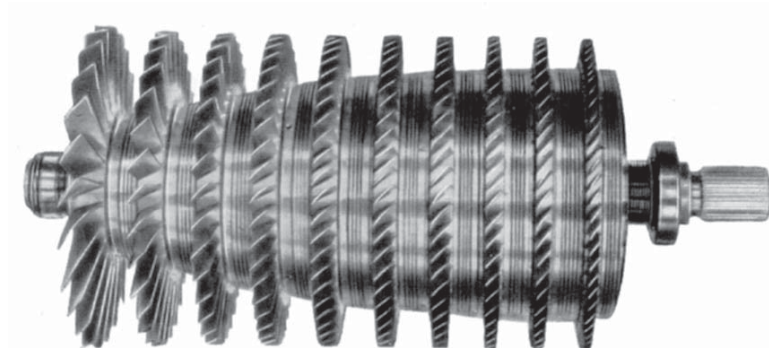

Compressor rotor

The combustion chamber is attached to the rear flange of the compressor casing.

The compressor comes to run at the operating speed and operates at lower RPM without surging due to bleeding some amount of air into the atmosphere through special valves.

The inefficient air leakage is eliminated by the labyrinth seals fitted between the rotor and stator, thereby increasing compressor efficiency.

The constant compressor RPM at the operating power conditions, moderate circumferential speeds and specific design features ensure high reliability of compressor operation during its whole service life.

COMBUSTION CHAMBER ASSEMBLY

The combustion chamber assembly is the engine load-bearing unit which takes up the turbine weight, forces and moments that emerge in the chamber and turbine during engine operation.

The assembly comprises combustion chamber casing, main fuel nozzles (gas burners), flame igniters, fuel manifold and a number of small assemblies.

The combustion chamber casing is a welded structure made of stainless steel.

The annular type combustion chamber is made of heat-resistant sheet material and provided with ten domes welded to the front ring.

The design of combustion chamber ensures ignition and fast flame transfer at starting.

The optimum combustion process combined with the effective system of sublayer cooling of walls provide for stable operation of combustion chamber at all power conditions as well as uniform temperature pattern at the turbine inlet and high operational reliability of combustion chamber throughout the entire service life.

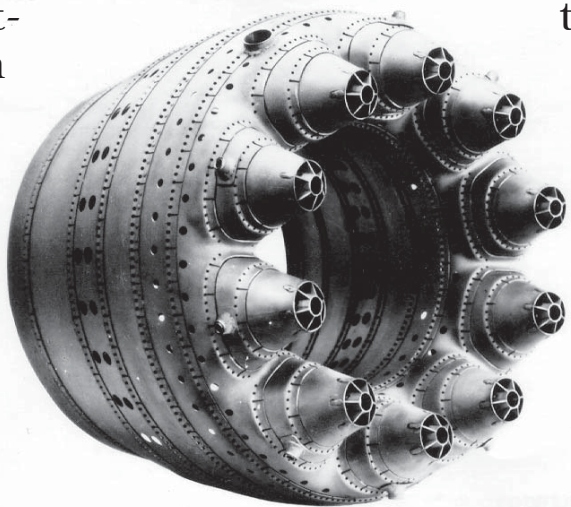

Combustion chamber

TURBINE

The axial-flow reaction turbine is designed to convert thermal energy of hot gases into mechanical work spent to rotate engine rotor, compressor and engine accessories and to transmit excessive power to the generator shaft.

A cantilever type turbine rotor comprises three rotor wheels and a shaft which are bolted to each other.

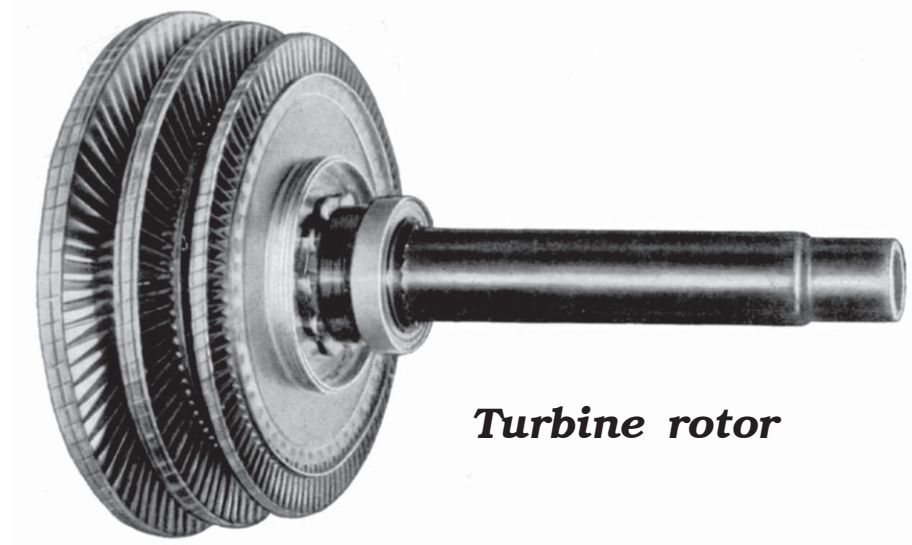

The shrouded turbine blades are fitted in pairs into the disk fir-tree slots.

Manufacture of disks, blades and other parts operating at high temperature from high temperature and heat-resistant materials and their effective cooling by air bled downstream of the compressor ensure turbine reliable operation.

High turbine efficiency is achieved due to use of the labyrinth seals which reduce gas leakage through radial clearances between the rotor and stator components.

The engine lubrication is effected on the principle of closed system in which the delivered and scavenged oils continuously circulate in a closed loop. The oil flows from the oil tank into the oil system as required to compensate for the oil consumed during engine operation.

All internal chambers of the engine are vented to provide for normal operation of the oil system and seals.

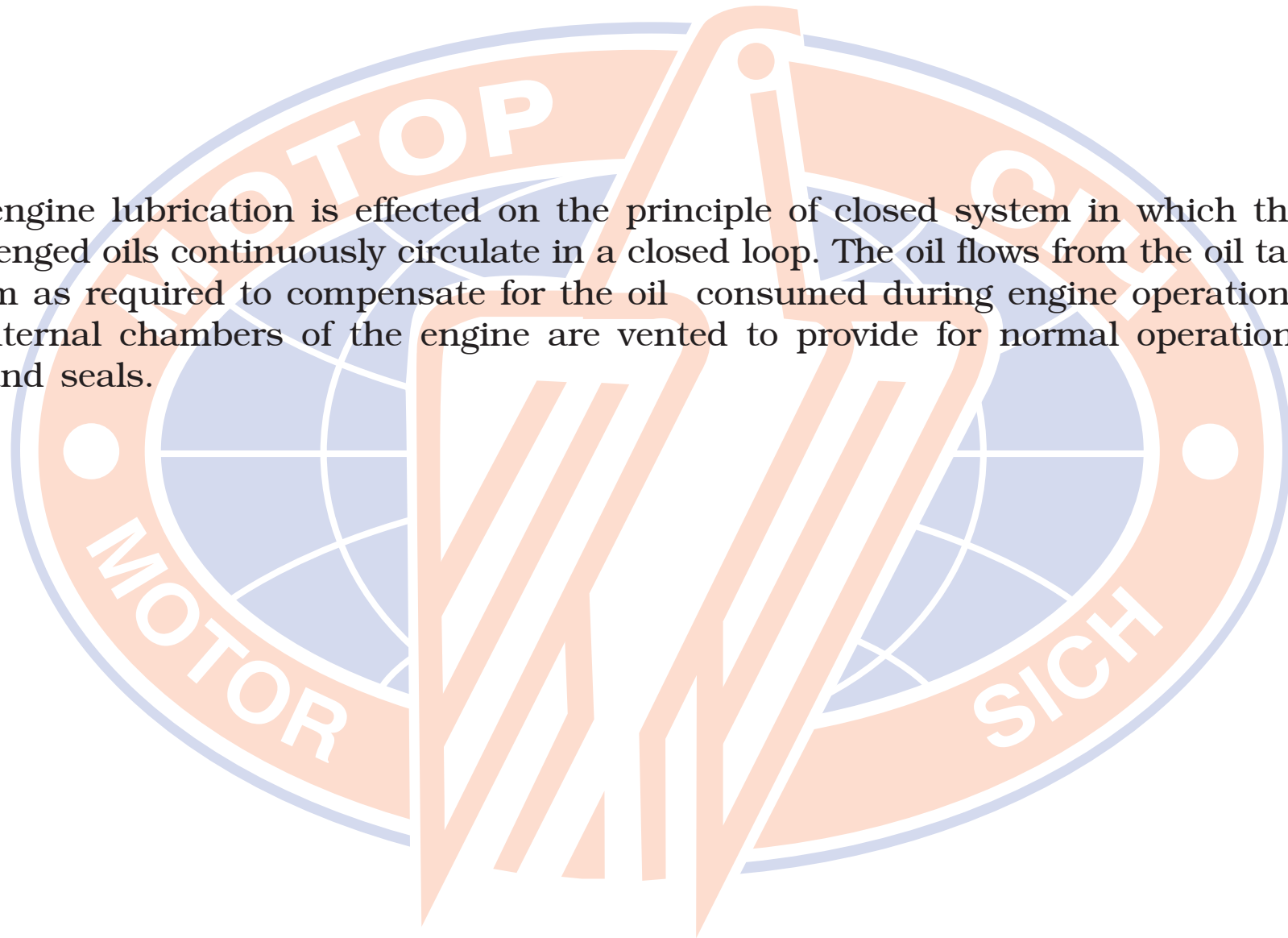

STARTING SYSTEM

Idle power RPM are attained by the engine rotor automatically. The rotor is spinned by two starter-generators.

To ensure compressor steady operation at starting, the air is allowed to be discharged into the atmosphere. The rotational speed and respective fuel consumption are controlled by the fuel control unit.

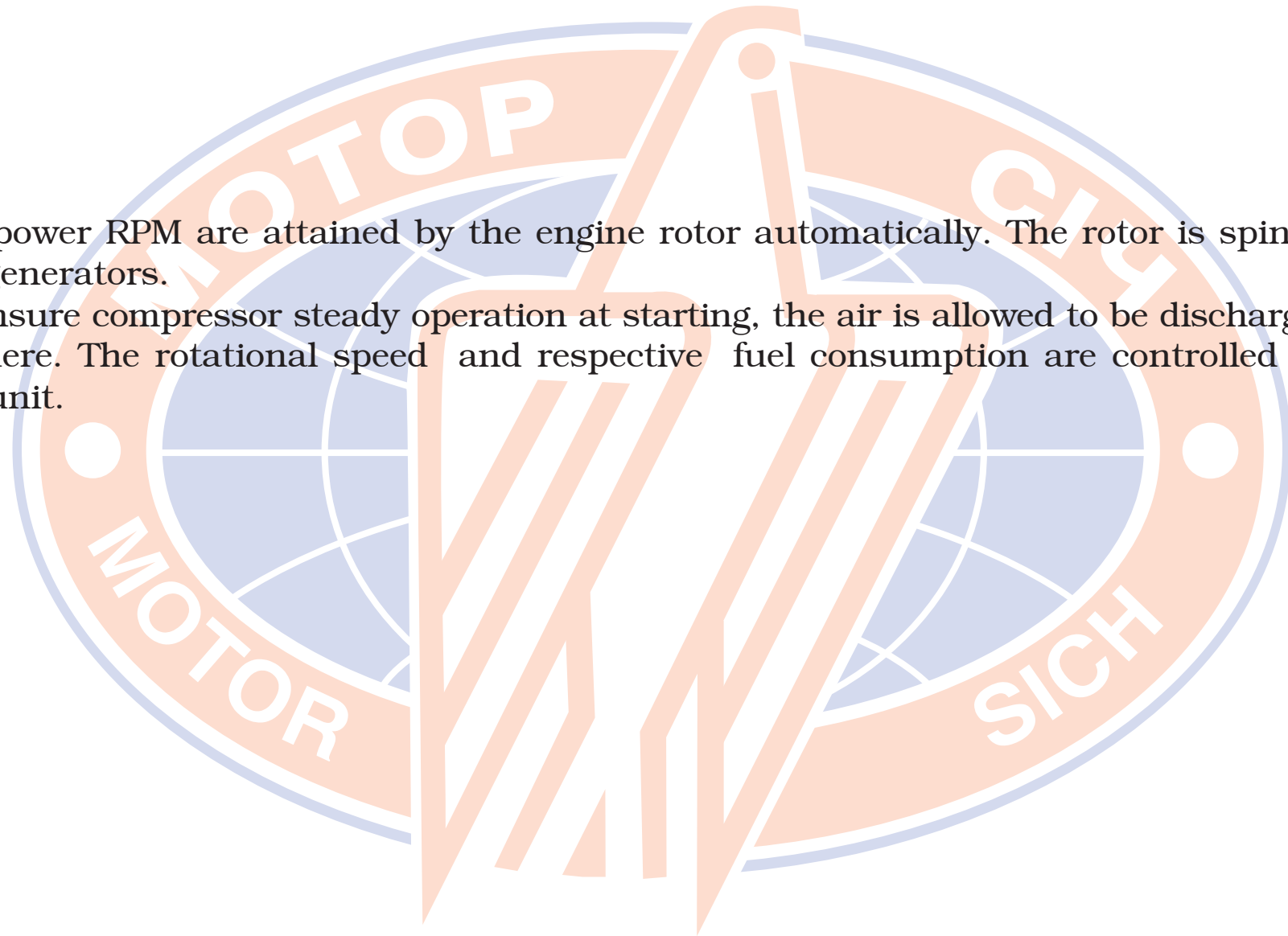

AI-20DMN
AI-20DME
AI-20DMNCh
AI-20DMECh

ANTI-ICING SYSTEM

A special unit warns about ice formation at the engine inlet. The hot air for heating compressor inlet guide vanes and other components, located at the engine inlet, is supplied by means of an electric actuator through the linkage system.

The internal chambers of front casing ribs are constantly heated with the hot circulating oil.

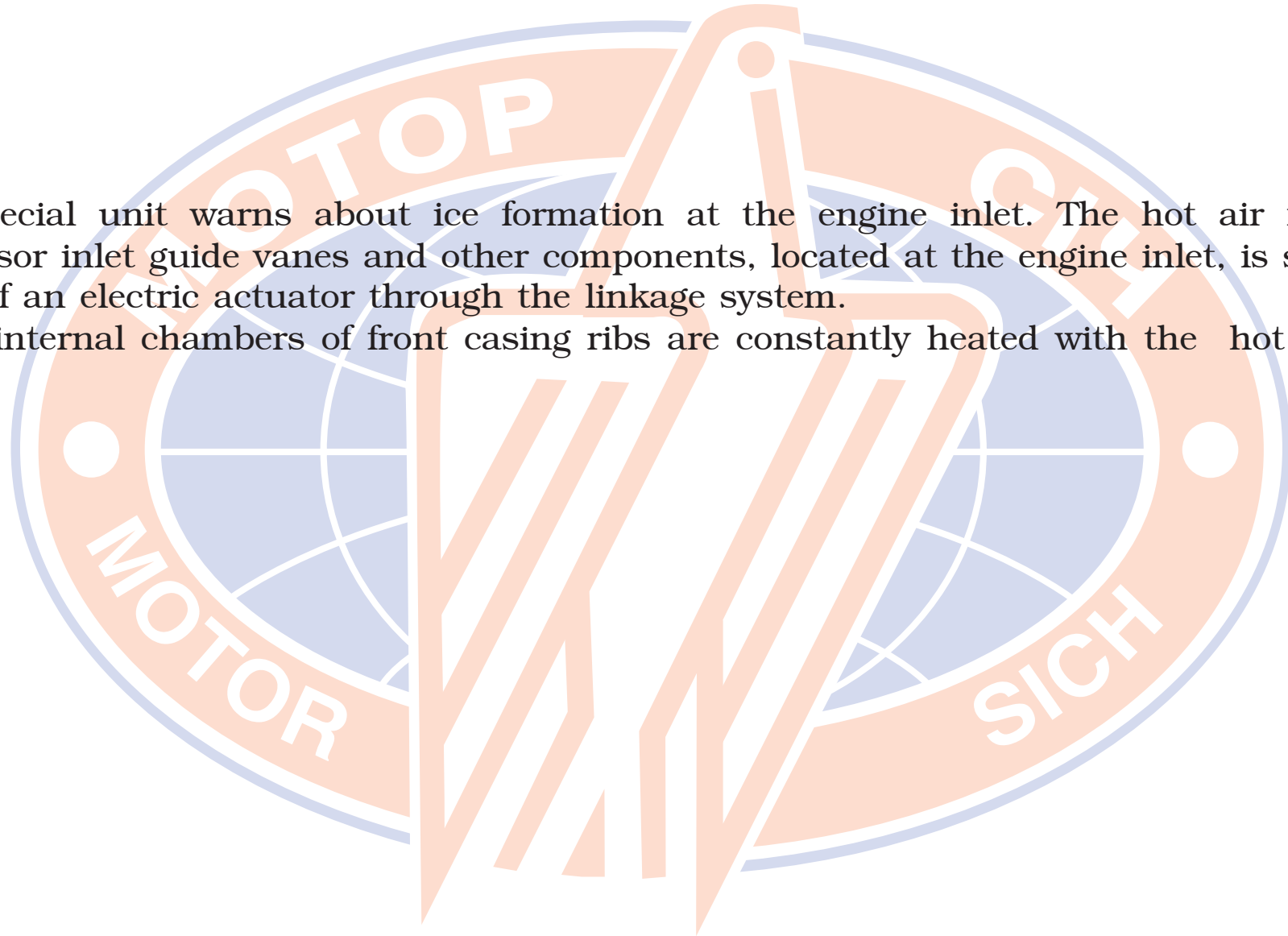

MOUNTING ENGINE ON POWER GENERATING UNIT FRAME

The engine is mounted with the help of four trunnions, two of them being located on the front casing in horizontal plane and the other two on the flange of the compressor-to-combustion chamber casings joint at 7 deg angle to the horizontal axis.

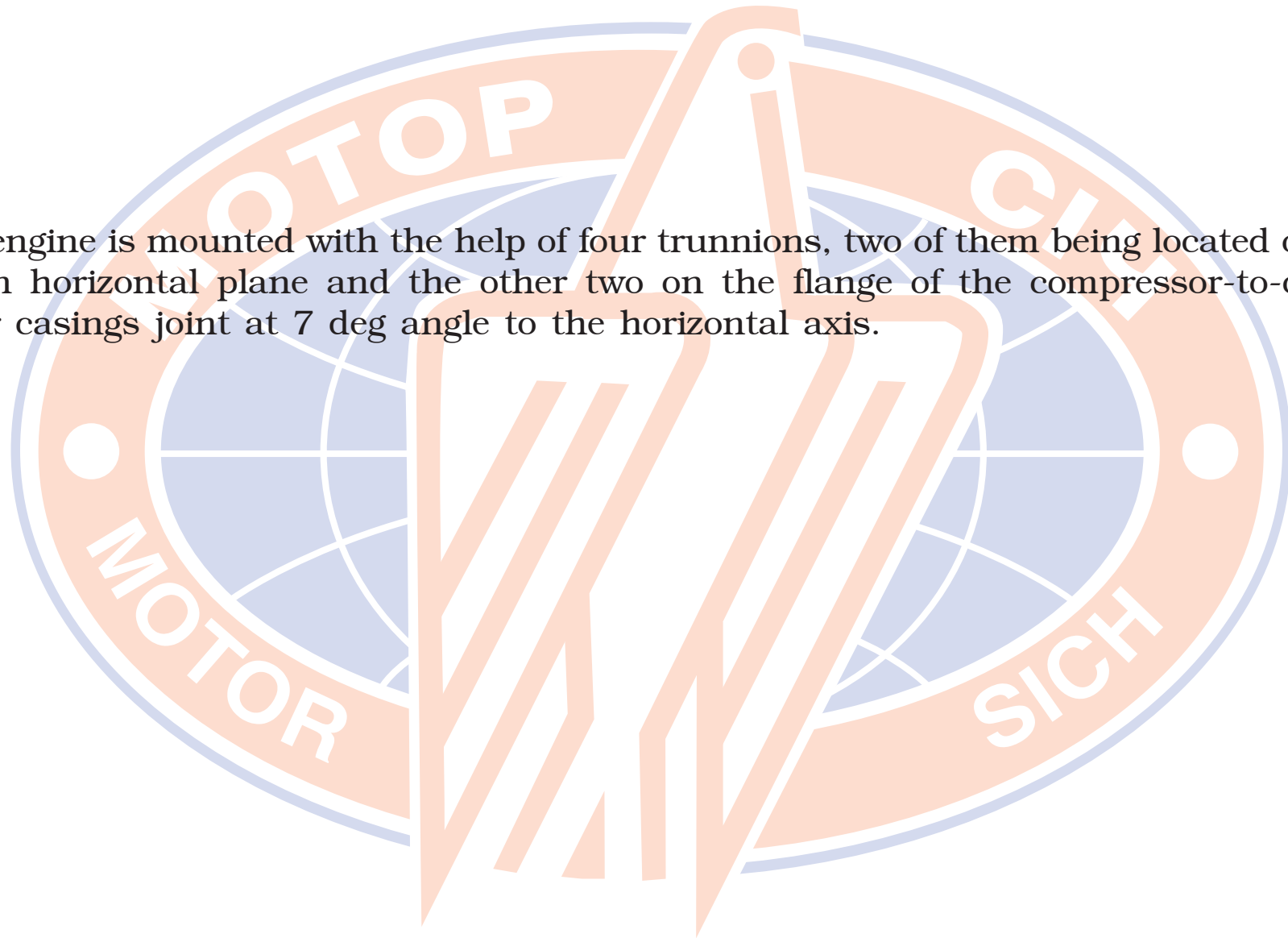

AI-20DMN
AI-20DME
AI-20DMNCh
AI-20DMECh

DELIVERY SET

The individual set of spare parts and the engine operation and maintenance publications are delivered with the engine.

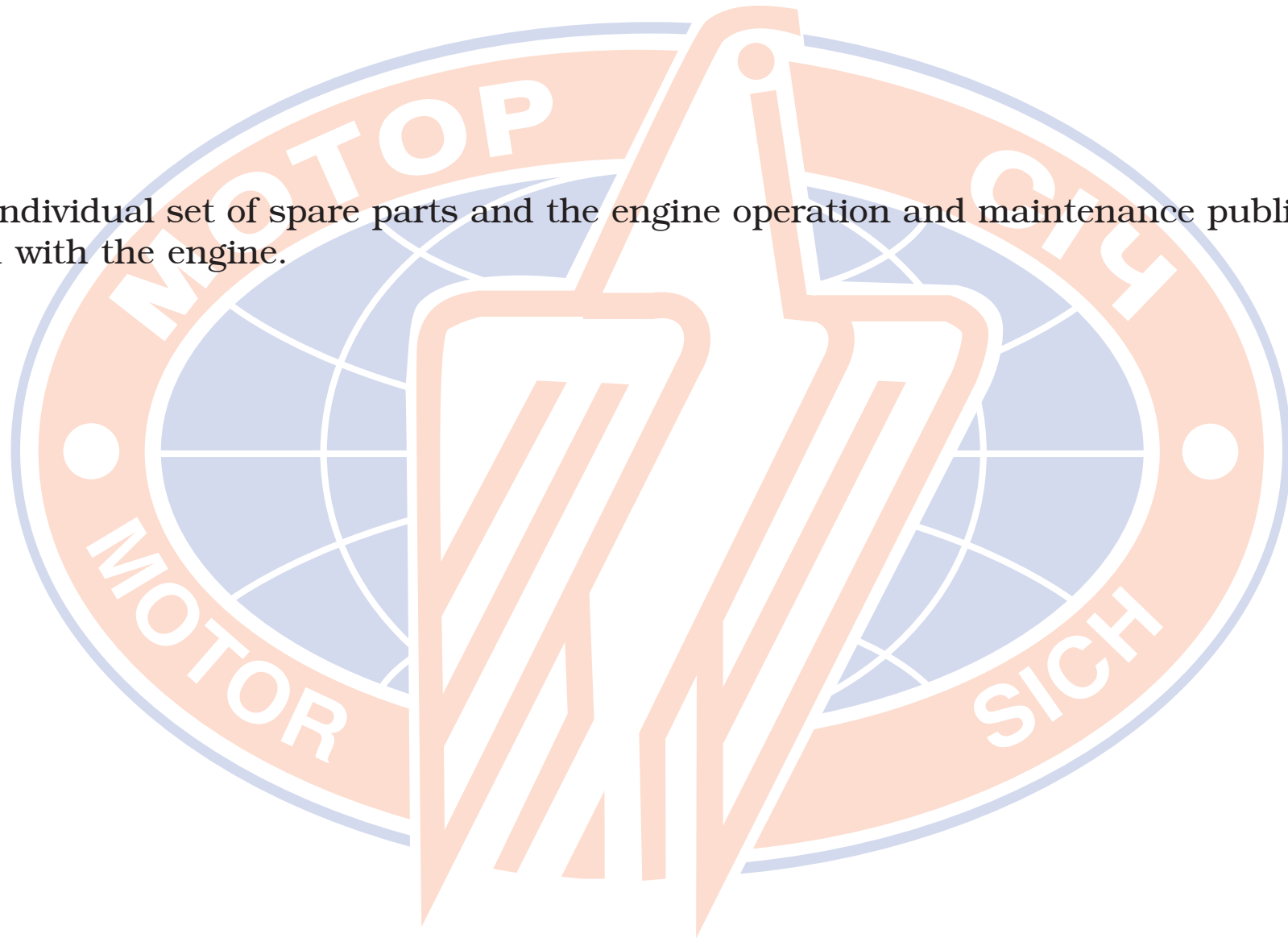

In-service maintenance provides for the following:

- service attendance by the manufacturer,
- low operation expenditures,
- low maintenance expenses,
- high operational reliability,
- flexibility and timeliness in eliminating faults,
- servicing at any place of the world,
- technical servicing on the 'on condition' basis,
- deputing Manufacturer's specialists for start-up period and, if necessary, for any period of operation,
- theoretical and practical training of Customer's specialists at the manufacturing plant or at the operation site in any place of the world,
- providing the Customer with information thus making it possible to avoid mistakes when operating our engines.

The experience in supervising engines by Motor Sich JSC specialists in service numbers dozens of years.

REPAIR SERVICING

In performing repair servicing the manufacturer is concerned with:

- control of all operations involved,
- delivery of necessary parts, units and other articles for the local repair in service,
- overhaul of the engine at the manufacturing plant with assignment of the original overhaul life and original preset characteristics (basic data) being restored,
- cooperation with the companies which are intended to establish repair facilities of their own.

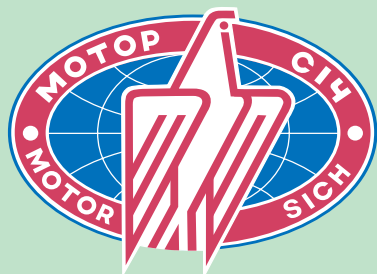

MOTOR SICH JSC
Zaporozhye 69068
Ukraine

Phone.: (380612) 61-49-53
Fax: (380612) 61-45-52
65-01-60

E-mail: untv.vtf@motorsich.com